



CE EMC

TEST REPORT

For

Wide-Temperature Isolated RS-422/485 Repeater

Model: ADAM-4510I

Trade Name: ADVANTECH

Issued to

Advantech Co., Ltd.

**No. 1, Alley 20, Lane 26, Rueiguang Road,
Neihu District, Taipei 114, R.O.C.**

Issued by



**Compliance Certification Services Inc.
Hsintien Lab.**

**No. 165, Chunghsen Road, Hsintien City
Taipei Hsien, Taiwan**

TEL: (02) 2217-0894

FAX: (02) 2217-1029

Note: This report shall not be reproduced except in full, without the written approval of Compliance Certification Services Inc. Ltd. This document may be altered or revised by Compliance Certification Services Inc. personnel only, and shall be noted in the revision section of the document.

**TABLE OF CONTENTS**

1	TEST RESULT CERTIFICATION	4
2	EUT DESCRIPTION	5
3	TEST METHODOLOGY	6
3.1	EUT SYSTEM OPERATION	6
3.2	DECISION OF FINAL TEST MODE	6
4	SETUP OF EQUIPMENT UNDER TEST	7
5	FACILITIES AND ACCREDITATIONS	8
5.1	FACILITIES	8
5.2	LABORATORY ACCREDITATIONS AND LISTINGS	8
6	INSTRUMENT AND CALIBRATION	9
6.1	MEASURING INSTRUMENT CALIBRATION	9
6.2	TEST AND MEASUREMENT EQUIPMENT	9
7	LINE CONDUCTED & RADIATED EMISSION TEST	12
7.1	LIMIT	12
7.1.1	EN 55022	12
7.1.2	EN 55011	13
7.2	TEST PROCEDURE OF LINE CONDUCTED EMISSION	14
7.2.1	EN 55022	14
7.2.2	EN 55011	15
7.3	TEST PROCEDURE OF COMMON MODE CONDUCTED EMISSION FOR TELECOMMUNICATION PORT	17
7.3.1	EN55022	17
7.4	TEST PROCEDURE OF RADIATED EMISSION	18
7.4.1	EN 55022	18
7.4.2	EN 55011	20
7.5	TEST RESULTS	22
8	POWER HARMONICS TEST	24
9	POWER VOLTAGE FLUCTUATION / FLICKER TEST	26
10	ELECTROSTATIC DISCHARGE (ESD) IMMUNITY TEST	28
10.1	EN 55024	28
10.2	EN 61000-6-2	31
11	RADIATED ELECTROMAGNETIC FIELD IMMUNITY TEST	35
11.1	EN 55024	35
11.2	EN 61000-6-2	38
12	FAST TRANSIENTS/BURST IMMUNITY TEST	41



12.1 EN 55024..... 41
12.2 EN 61000-6-2 43

13 SURGE IMMUNITY TEST 45

13.1 EN 55024..... 45
13.2 EN 61000-6-2 47

**14 CONDUCTED DISTURBANCE/INDUCED RADIO-FREQUENCY FIELD
IMMUNITY TEST..... 49**

14.1 EN 55024..... 49
14.2 EN 61000-6-2 51

15 POWER FREQUENCY MAGNETIC FIELD IMMUNITY TEST..... 53

15.1 EN 55024..... 53
15.2 EN 61000-6-2 55

16 VOLTAGE DIPS / SHORT INTERRUPTIONS..... 57

16.1 EN 55024..... 57
16.2 EN 61000-6-2 59

APPENDIX I - PHOTOGRAPHS OF TEST SETUP 61



1 TEST RESULT CERTIFICATION

Applicant: **Advantech Co., Ltd.**
No. 1, Alley 20, Lane 26, Rueiguang Road,
Neihu District, Taipei 114, R.O.C.

Manufacturer: **Advantech Co., Ltd.**
No. 1, Alley 20, Lane 26, Rueiguang Road,
Neihu District, Taipei 114, R.O.C.

Equipment Under Test: Wide-Temperature Isolated RS-422/485 Repeater

Trade Name: ADVANTECH

Model: ADAM-4510I

Detailed EUT Description: See Item 2 of this report

Date of Test: June 1, 2006

Applicable Standard	Class/Limit/Criterion	Test Result
EN 55011: 1998 + A1: 1999 + A2: 2002	Group 1 / Class A	No non-compliance noted
EN 55022: 1998 + A1: 2000 + A2: 2003	Class A	No non-compliance noted
EN 61000-3-2: 2000	Class D	N/A
EN 61000-3-3: 1995 + A1: 2001	Limit	N/A
EN 61000-6-2: 2001 (EN 55024: 1998 + A1: 2001 + A2: 2003), including		
IEC 61000-4-2: 1995 + A1: 1998 + A2: 2000	Criterion B	No non-compliance noted
IEC 61000-4-3: 2002 + A1: 2002	Criterion A	No non-compliance noted
IEC 61000-4-4: 1995 + A1: 2000 + A2: 2001	Criterion B	No non-compliance noted
IEC 61000-4-5: 1995 + A1: 2000	Criterion B	No non-compliance noted
IEC 61000-4-6: 1996 + A1: 2000	Criterion A	No non-compliance noted
IEC 61000-4-8: 1993 + A1: 2000	Criterion A	No non-compliance noted
IEC 61000-4-11: 1994 + A1: 2000	Criterion B/C/C	N/A
Deviation from Applicable Standard		
As the customers required, we adopt the above standards for testing.		

The above equipment was tested by Compliance Certification Services Inc. for compliance with the requirements set forth in the EMC Directive 89/336/EMC and the technical standards mentioned above. The results of testing in this report apply only to the product/system, which was tested. Other similar equipment will not necessarily produce the same results due to production tolerance and measurement uncertainties.

Approved by:

David Wang
Manager of Hsintien Laboratory
Compliance Certification Services Inc.

Reviewed by:

Vince Chiang
Assistant Manager of Hsintien Laboratory
Compliance Certification Services Inc.



2 EUT DESCRIPTION

Product	Wide-Temperature Isolated RS-422/485 Repeater
Trade Name	ADVANTECH
Model	ADAM-4510I
Housing Type	Plastic
EUT Power Rating	10-48VDC
OSC/Clock Frequencies	14.7MHz

Model Differences

Model Name	Report No.	Difference	Tested (Checked)
ADAM-4520I	60530204	Original	<input checked="" type="checkbox"/>
ADAM-4510I	60616204	For marketing purpose only.	

I/O PORT OF EUT

I/O PORT TYPE	Q'TY	TESTED WITH
1). SIO Port	1	1

Note: None.



3 TEST METHODOLOGY

3.1 EUT SYSTEM OPERATION

1. All peripherals connect EUT to test.

Note: Test program is self-repeating throughout the test.

3.2 DECISION OF FINAL TEST MODE

1. The following test mode were scanned during the preliminary test:

Mode:

1	NORMAL MODE
---	-------------

2. After the preliminary scan, the following test mode was found to produce the highest emission level.

Conduction: N/A *(The subject equipment is not intended to be connected to AC mains supply. Therefore, this test is not applicable.)*

Radiation: Mode 1

Then, the EUT configuration and cable configuration of the above highest emission mode was chosen for all final test items.



4 SETUP OF EQUIPMENT UNDER TEST

Setup Diagram

See test photographs attached in Appendix I for the actual connections between EUT and support equipment.

Support Equipment

Peripherals Devices:

No	Equipment	Model	Serial No.	FCC ID / BSMI ID	Trade Name	Data Cable	Power Cord
1	DC Power Supply	S-201-12	N/A	N/A	MEAN	GND: Unshielded, 0.5m DC: Unshielded, 0.3mx2	Unshielded, 1.8m
2	Wide-Temperature Isolated RS-422/485 Repeater	ADAM-4520I	N/A	N/A	ADVANTECH	Unshielded, 0.1mx6	N/A
3	COM Load	N/A	N/A	N/A	N/A	Shielded, 1.0m	N/A

Note: All the above equipment/cables were placed in worse case positions to maximize emission signals during emission test.

Grounding: Grounding was in accordance with the manufacturer's requirements and conditions for the intended use.

5 FACILITIES AND ACCREDITATIONS

5.1 FACILITIES







All measurement facilities used to collect the measurement data are located at CCS Taiwan Hsintien Lab at No. 165, Chungshen Road, Hsintien City, Taipei Hsien, Taiwan.

The measurement facilities are constructed in conformance with the requirements of CISPR 16-1, ANSI C63.4 and other equivalent standards.

5.2 LABORATORY ACCREDITATIONS AND LISTINGS

The test facilities used to perform Electromagnetic compatibility tests are registered or accredited by the organizations listed in the following table which includes the recognized scope specifically.

This accredited organization maintains A2LA accreditation to ISO/IEC 17025 for the specific test listed in A2LA Certificate # 0824-01. The test results included in this report, however, are not covered by this accreditation.

Country	Agency	Scope of Accreditation	Logo
USA	A2LA	CFR 47, FCC Part 15/18; AS/NZS 3548; VCCI V3; CNS 13438; CNS 13439; CNS 13783; CNS 14115; CISPR 11/EN 55011; CISPR 14-1/EN 55014-1; CISPR 15/EN 55015; CISPR 22/EN 55022; EN 50081-1/EN 61000-6-3; EN 50082-1/EN 61000-6-4; IEC/EN 61000-4-2, IEC/EN 61000-4-3, IEC/EN 61000-4-4, IEC/EN 61000-4-5, IEC/EN 61000-4-6, IEC/EN 61000-4-8, IEC/EN 61000-4-11, IEC/EN 61000-3-2, IEC/EN 61000-3-3; CISPR 24/EN 55024; CISPR 14-2/EN 55014-2; EN 50081-2/EN 61000-6-1; EN 50082-2/EN 61000-6-2.	
USA	FCC	3/10 meter Open Area Test Sites to perform FCC Part 15/18 measurements	 250366
Japan	VCCI	3/10 meter Open Area Test Sites and Line Conducted Test Room to perform conducted/radiated measurements	 R-2265/1630-4 C-1882/2146
Norway	NEMKO	EN 50081-1/2, EN 50082-1/2, IEC 61000-6-1/2/3/4, EN 50091-2, EN 50130-4, EN 55011, EN 55013, EN 55014-1/2, EN 55015, EN 55022, EN 55024, EN 61000-3-2/3, EN 61326-1, IEC 61000-4-2/3/4/5/6/8/11, Cisp 16-1/2/3/4	 ELA 103
Taiwan	CNLA	47 CFR FCC Part 15 Subpart B, EN 61000-3-2, EN 61000-3-3, CNS 13439, CNS 13783-1, CNS 13438, AS/NZS 3548, VCCI, CNS 13022-1/2/3, EN 55022, EN 55013, EN 55014-1, EN 61000-4-2/3/4/5/6/8/11, ENV 50204, ENV 50141, ENV 50142	 Testing Laboratory 1108
Taiwan	BSMI	CNS 13438, CNS 13783-1, CNS 13439	 SL2-IN-E-0005 SL2-A1-E-0005 SL2-R1-E-0005 SL2-R2-E-0005
Canada	Industry Canada	RSS212, Issue 1	 IC 5742

Note: No part of this report may be used to claim or imply product endorsement by CNLA, A2LA or other government agency.



6 INSTRUMENT AND CALIBRATION

6.1 MEASURING INSTRUMENT CALIBRATION

The measuring equipment utilized to perform the tests documented in this report has been calibrated once a year or in accordance with the manufacturer's recommendations, and is traceable to recognized national standards.

6.2 TEST AND MEASUREMENT EQUIPMENT

The following list contains measurement equipment used for testing. The equipment conforms to the requirement of CISPR 16-1, ANSI C63.2 and other required standards.

Calibration of all test and measurement, including any accessories that may effect such calibration, is checked frequently to ensure the accuracy. Adjustments are made and correction factors are applied in accordance with the instructions contained in the respective manual.

Equipment Used for Emission Measurement

Open Area Test Site # K				
EQUIPMENT	MFR	MODEL	SERIAL NUMBER	CAL. DUE
SITE NSA	CCS	K Site	N/A	10/01/2006
MEASURE RECEIVER	SCHAFFNER	SCR3501	412	05/18/2007
SPECTRUM ANALYZER	ADVANTEST	R3132	120900029	No Calibration Required
ANTENNA	SCHAFFNER	CBL 6112B	2846	05/26/2007
PRE-AMPLIFIER	SCHAFFNER	CPA9231A	3639	10/08/2006
CABLE	SUHNER	RG 214	N-TYPE #K2	02/17/2007
DECOUPLING NETWORK	FCC	F-201-DCN-5-6MM	22, 24	08/24/2006

Note: The measurement uncertainty is less than +/- 3.36dB, which is evaluated as per the NAMAS NIS 81 and CISPR/A/291/CDV.

Conducted Emission Test Site # A				
EQUIPMENT	MFR	MODEL	SERIAL NUMBER	CAL. DUE
TEST RECEIVER	R&S	ESHS20	840455/006	02/06/2007
LISN (EUT)	SCHWARZBECK	NSLK 8127	8127382	01/02/2007
LISN	SOLAR	8012-50-R-24-BNC	8305114	01/02/2007
BNC CABLE	JYE BAO	RG-223/U	BNC A 2	10/08/2006
THERMO-HYGRO METER	TOP	HA-202	9303-1	02/22/2007

Note: The measurement uncertainty is less than +/- 2.83dB, which is evaluated as per the NAMAS NIS 81 and CISPR/A/291/CDV.



Power Harmonic & Voltage Fluctuation/Flicker Test Site (EN 61000-3-2&-3-3)			
Manufacturer/Type	Model No.	Serial No.	Cal. Due
Schaffner / Signal Conditioning Unit	CCN 1000-1	72122	12/01/2006
Schaffner / 5KVA AC Power Source	NSG 1007	55131	No Calibration Required

Equipment Used for Immunity Measurement

ESD Test Site (EN 61000-4-2)			
Manufacturer/Type	Model No.	Serial No.	Cal. Due
Schaffner / ESD Simulator	NSG 438	129	04/24/2007
Sato / Aneroid Barometer	7610-20	89090	08/29/2006
TOP / Thermo-Hygro meter	HA-202	9303-1	02/22/2007

Radiated Electromagnetic Field Immunity Test Site (EN 61000-4-3)			
Manufacturer/Type	Model No.	Serial No.	Cal. Due
Calibration of Field	Chamber#RS	200604H/V-2	04/11/2007
Agilent / Signal Generator	E4421B	MY43350597	05/17/2007
AR / Electric Field Probe	FP6001	305650	03/15/2007
Boonton / RF Voltmeter	9200B	328001AE	02/08/2007
BNC / Function Generator	625A	25451	02/08/2007
AR / Amplifier	100W1000M1	17564	No Calibration Required
AR / Direction Coupler	DC6180A	312189	No Calibration Required
AR / Broadband Antenna	AT1080	311819	No Calibration Required
TOP / Thermo-Hygro meter	HA-202	9303-2	02/22/2007

Fast Transients/Burst Test Site (EN 61000-4-4)			
Manufacturer/Type	Model No.	Serial No.	Cal. Due
Schaffner / EFT Generator	BEST EMC V2.3	200031A024SC	11/07/2006
Schaffner / Capacitive Clamp	N/A	N/A	No Calibration Required



Surge Immunity Test Site (EN 61000-4-5)			
Manufacturer/Type	Model No.	Serial No.	Cal. Due
Schaffner / Surger Generator	BEST EMC V2.3	200031A024SC	11/07/2006
Schaffner / Signal and Data Lines Coupling Network	CDN118	19328	No Calibration Required

CS test (EN 61000-4-6)			
Manufacturer/Type	Model No.	Serial No.	Cal. Due
Schaffner / RF Generator	NSG 2070-1	1061	08/03/2006
Schaffner / CDN	CDN M316	19600	08/02/2006
Schaffner / CDN	CDN M216	19294	08/02/2006
FCC / CDN	FCC-801-M3-16A	99122	08/02/2006
Schaffner / EM Clamp	KEMZ 801	19227	02/19/2007
Schaffner / CDN	CDN T002	15881	01/12/2007
FCC / CDN	FCC-801-T8-RJ45	04025	06/23/2006
Schaffner / Attenuator	INA2070-1	2061	No Calibration Required
FCC / CDN	FCC-801-T4-RJ45	04031	08/02/2006

Power Frequency Magnetic Field Immunity test (EN 61000-4-8)			
Manufacturer/Type	Model No.	Serial No.	Cal. Due
Schaffner / Induction Coil Interface	INA 21141	6009	No Calibration Required
Schaffner / 5KVA AC Power Source	NSG 1007	55131	No Calibration Required
CHY/ TRMS Clamp Meter	932C	2K0900285	10/16/2006
Sypris / Magnetic Field Meter	4080	0247	01/23/2007

Voltage Dips/Short Interruption and Voltage Variation Immunity test (EN 61000-4-11)			
Manufacturer/Type	Model No.	Serial No.	Cal. Due
Schaffner / Dips/Interruption/Variations Tester	BEST EMC V2.3	200031A024SC	11/07/2006
Protronix / Digital Power Meter	1201	201091	08/24/2006



7 LINE CONDUCTED & RADIATED EMISSION TEST

7.1 LIMIT

7.1.1 EN 55022

Maximum permissible level of Line Conducted Emission

FREQUENCY (MHz)	Class A (dBuV)		Class B (dBuV)	
	Quasi-peak	Average	Quasi-peak	Average
0.15 - 0.5	79	66	66 - 56	56 - 46
0.50 - 5.0	73	60	56	46
5.0 - 30.0	73	60	60	50

Note: The lower limit shall apply at the transition frequency.

Maximum permissible level of Common Mode Conducted Emission (Telecommunication Ports)

CLASS A

FREQUENCY (MHz)	Voltage Limit (dBuV)		Current Limit (dBuA)	
	Quasi-peak	Average	Quasi-peak	Average
0.15 - 0.5	97 - 87	84 - 74	53 - 43	40 - 30
0.5 - 30.0	87	74	43	30

CLASS B

FREQUENCY (MHz)	Voltage Limit (dBuV)		Current Limit (dBuA)	
	Quasi-peak	Average	Quasi-peak	Average
0.15 - 0.5	84 - 74	74 - 64	40 - 30	30 - 20
0.5 - 30.0	74	64	30	20

Note: The lower limit shall apply at the transition frequency.

Maximum permissible level of Radiated Emission measured at 10 meter

FREQUENCY (MHz)	Class A (dBuV/m)	Class B (dBuV/m)
	Quasi-peak	Quasi-peak
30 - 230	40	30
230 - 1000	47	37

Note: The lower limit shall apply at the transition frequency.

**7.1.2 EN 55011****Maximum permissible level of Mains terminal disturbance voltage
(Conducted Emission)****CLASS A**

FREQUENCY (MHz)	Group 1		Group 2		Group 2*	
	Quasi-peak (dBuV)	Average (dBuV)	Quasi-peak (dBuV)	Average (dBuV)	Quasi-peak (dBuV)	Average (dBuV)
0.15 - 0.5	79	66	100	90	130	120
0.50 - 5.0	73	60	86	76	125	115
5.0 - 30.0	73	60	90 Decreasing linearly with logarithm of frequency to 70	80 60	115	105

Note: The lower limit shall apply at the transition frequency

Care should be taken to comply with leakage current requirements.

CLASS B

FREQUENCY (MHz)	Group 1 & 2	
	Quasi-peak (dBuV)	Average (dBuV)
0.15 - 0.5	66 Decreasing linearly with logarithm of frequency to 56	56 Decreasing linearly with logarithm of frequency to 46
0.50 - 5.0	56	46
5.0 - 30.0	60	50

Note: The lower limit shall apply at the transition frequency

Care should be taken to comply with leakage current requirements.

Maximum permissible level of Radiated Emission measured at 10 meter

FREQUENCY (MHz)	Measured on a test site		Measured in situation
	Group 1, class A	Group 1, class B	Group 1, class A Limits with measuring distance 30 m from exterior wall outside the building in which the equipment is situated
	Quasi-peak (dBuV/m)	Quasi-peak (dBuV/m)	Quasi-peak (dBuV/m)
0.15 - 30	Under consideration	Under consideration	Under consideration
30 - 230	40	30	30
230 - 1000	47	37	37

Note: The lower limit shall apply at the transition frequency.



7.2 TEST PROCEDURE OF LINE CONDUCTED EMISSION

7.2.1 EN 55022

Procedure of Preliminary Test

- The EUT was set up as per the test configuration to simulate typical usage per the user's manual. When the EUT is a tabletop system, a wooden table with a height of 0.8 meters is used and is placed on the ground plane as per EN 55022 (see Test Facility for the dimensions of the ground plane used). When the EUT is a floor-standing equipment, it is placed on the ground plane which has a 3-12 mm non-conductive covering to insulate the EUT from the ground plane.
- Support equipment, if needed, was placed as per EN 55022.
- All I/O cables were positioned to simulate typical actual usage as per EN 55022.
- The test system with EUT received AC power, 230V/50Hz, through a Line Impedance Stabilization Network (LISN), which supplied power source and was grounded to the ground plane.
- All support equipment received power from a second LISN.
- The EUT test program was started. Emissions were measured on each current carrying line of the EUT using an EMI Test Receiver connected to the LISN powering the EUT.
- The Receiver scanned from 150kHz to 30MHz for emissions in each of the test modes.
- During the above scans, the emissions were maximized by cable manipulation.
- The test mode(s) described in Item 3.2 were scanned during the preliminary test.
- After the preliminary scan, we found the test mode described in Item 3.2 producing the highest emission level.
- The EUT configuration and cable configuration of the above highest emission level were recorded for reference of the final test.

Procedure of Final Test

- EUT and support equipment were set up on the test bench as per the configuration with highest emission level in the preliminary test.
- A scan was taken on both power lines, Line 1 and Line 2, recording at least the six highest emissions. Emission frequency and amplitude were recorded into a computer in which correction factors were used to calculate the emission level and compare reading to the applicable limit. If EUT emission level was less -2dB to the Average limit in Q.P. mode, then the emission signal was re-checked using an Average detector.
- The test data of the worst-case condition(s) was recorded.

**Data Sample:**

Freq. MHz	Read Level dBuV	Factor dB	Level dBuV	Limit dBuV	Over Limit dB	Reading Type (P/Q/A)	Line (L1/L2)
x.xx	42.95	0.55	43.50	73	-29.50	Q	L1

- Freq. = Emission frequency in MHz
Read Level = Uncorrected Analyzer/Receiver reading
Factor = Insertion loss of LISN + Cable Loss
Level = Read Level + Factor
Limit = Limit stated in standard
Over Limit = Reading in reference to limit
P = Peak Reading
Q = Quasi-peak Reading
A = Average Reading
L1 = Hot side
L2 = Neutral side

Calculation Formula

Over Limit (dB) = Level (dBuV) – Limit (dBuV)

7.2.2 EN 55011**Procedure of Preliminary Test**

- The EUT was set up as per the test configuration to simulate typical usage per the user's manual. When the EUT is a tabletop system, a wooden table with a height of 0.8 meters is used and is placed on the ground plane as per EN 55011 (see Test Facility for the dimensions of the ground plane used). When the EUT is a floor-standing equipment, it is placed on the ground plane which has a 3-12 mm non-conductive covering to insulate the EUT from the ground plane.
- Support equipment, if needed, was placed as per EN 55011.
- All I/O cables were positioned to simulate typical actual usage as per EN 55011.
- The test equipment EUT installed received AC power, 230V/50Hz, through a Line Impedance Stabilization Network (LISN), which supplied power source and was grounded to the ground plane.
- All support equipment received power from a second LISN.
- The EUT test program was started. Emissions were measured on each current carrying line of the EUT using an EMI Test Receiver connected to the LISN powering the EUT.
- The Receiver scanned from 150kHz to 30MHz for emissions in each of the test modes.
- During the above scans, the emissions were maximized by cable manipulation.
- The test mode(s) described in Item 3.2 were scanned during the preliminary test.



- After the preliminary scan, we found the test mode described in Item 3.2 producing the highest emission level.
- The EUT configuration and cable configuration of the above highest emission level were recorded for reference of the final test.

Procedure of Final Test

- EUT and support equipment were set up on the test bench as per the configuration with highest emission level in the preliminary test.
- A scan was taken on both power lines, Line 1 and Line 2, recording at least the six highest emissions. Emission frequency and amplitude were recorded into a computer in which correction factors were used to calculate the emission level and compare reading to the applicable limit. If EUT emission level was less -2dB to the Average limit in Q.P. mode, then the emission signal was re-checked using an Average detector.
- The test data of the worst-case condition(s) was recorded.

Data Sample:

Freq. MHz	Read Level dBuV	Factor dB	Level dBuV	Limit dBuV	Over Limit dB	Reading Type (P/Q/A)	Line (L1/L2)
x.xx	42.95	0.55	43.50	73	-29.50	Q	L1

Freq. = Emission frequency in MHz
 Read Level = Uncorrected Analyzer/Receiver reading
 Factor = Insertion loss of LISN + Cable Loss
 Level = Read Level + Factor
 Limit = Limit stated in standard
 Over Limit = Reading in reference to limit
 P = Peak Reading
 Q = Quasi-peak Reading
 A = Average Reading
 L1 = Hot side
 L2 = Neutral side

Calculation Formula

Over Limit (dB) = Level (dBuV) – Limit (dBuV)



7.3 TEST PROCEDURE OF COMMON MODE CONDUCTED EMISSION FOR TELECOMMUNICATION PORT

7.3.1 EN55022

- Selecting ISN for unscreened cable or a current probe for screened cable to take measurement.
- The port of the EUT was connected to the remote side support equipment through the ISN/Current Probe and communication in normal condition.
- Making a overall range scan by using the test receiver controlled by controller and record at least six highest emissions for showing in the test report.
- Emission frequency and amplitude were recorded into a computer in which correction factors were used to calculate the emission level and compare reading to the applicable limit.
- In case of measuring on the screened cable, the current limit shall be applied, otherwise the voltage limit should be applied.
- The following test mode(s) were scanned during the preliminary test:
N/A
- After the preliminary scan, we found the following test mode(s) producing the highest emission level and test data of the worst case was recorded.

N/A

Data Sample:

Freq. MHz	Read Level dBuV	Factor dB	Level dBuV	Limit dBuV	Over Limit dB	Reading Type (P/Q/A)
x.xx	62.95	0.55	63.50	87	-23.50	Q

- Freq. = Emission frequency in MHz
 Read Level = Uncorrected Analyzer/Receiver reading
 Factor = Insertion loss of ISN + Cable Loss
 Level = Read Level + Factor
 Limit = Limit stated in standard
 Over Limit = Reading in reference to limit
 P = Peak Reading
 Q = Quasi-peak Reading
 A = Average Reading

Calculation Formula

Over Limit (dB) = Level (dBuV) – Limit (dBuV)



7.4 TEST PROCEDURE OF RADIATED EMISSION

7.4.1 EN 55022

Procedure of Preliminary Test

- The equipment was set up as per the test configuration to simulate typical usage per the user's manual. When the EUT is a tabletop system, a wooden turntable with a height of 0.8 meters is used which is placed on the ground plane. When the EUT is a floor-standing equipment, it is placed on the ground plane which has a 3-12 mm non-conductive covering to insulate the EUT from the ground plane.
- Support equipment, if needed, was placed as per EN 55022.
- All I/O cables were positioned to simulate typical usage as per EN 55022.
- The EUT received AC power source, 230V/50Hz, from the outlet socket under the turntable. All support equipment received power from another socket under the turntable.
- Mains cables, telephone lines or other connections to auxiliary equipment located outside the test are shall drape to the floor, be fitted with ferrite clamps or ferrite tubes placed on the floor at the point where the cable reaches the floor and then routed to the place where they leave the turntable. No. extension cords shall be used to mains receptacle.
- The antenna was placed at 10 meter away from the EUT as stated in EN 55022. The antenna connected to the Spectrum Analyzer via a cable and at times a pre-amplifier would be used.
- The Analyzer / Receiver quickly scanned from 30MHz to 1000MHz. The EUT test program was started. Emissions were scanned and measured rotating the EUT to 360 degrees and positioning the antenna 1 to 4 meters above the ground plane, in both the vertical and the horizontal polarization, to maximize the emission reading level.
- The test mode(s) described in Item 3.2 were scanned during the preliminary test:
- After the preliminary scan, we found the test mode described in Item 3.2 producing the highest emission level.
- The EUT and cable configuration, antenna position, polarization and turntable position of the above highest emission level were recorded for the final test.

Procedure of Final Test

- EUT and support equipment were set up on the turntable as per the configuration with highest emission level in the preliminary test.
- The Analyzer / Receiver scanned from 30MHz to 1000MHz. Emissions were scanned and measured rotating the EUT to 360 degrees, varying cable placement and positioning the antenna 1 to 4 meters above the ground plane, in both the vertical and the horizontal polarization, to maximize the emission reading level.



- Recorded at least the six highest emissions. Emission frequency, amplitude, antenna position, polarization and turntable position were recorded into a computer in which correction factors were used to calculate the emission level and compare reading to the applicable limit and only Q.P. reading is presented.

Data Sample:

Freq. MHz	Amptd dBuV/m	Margin dB	Limit dBuV/m	Reading dBuV	Factor dB/m	Reading Type (P/Q/A)	Pol. (H/V)
x.xx	26.2	-13.8	40	14	12.2	Q	H

Freq. = Emission frequency in MHz
 Reading = Uncorrected Analyzer/Receiver reading
 Factor = Antenna Factor + Cable Loss + Attenuator (3/6/10dB) – Amplifier Gain
 Amptd = Uncorrected Analyzer/Receiver reading + Factor
 Limit = Limit stated in standard
 Margin = Reading in reference to limit
 P = Peak Reading
 Q = Quasi-peak Reading
 A = Average Reading
 H = Antenna Polarization: Horizontal
 V = Antenna Polarization: Vertical

Calculation Formula

Margin (dB) = Amptd (dBuV/m) – Limit (dBuV/m)



7.4.2 EN 55011

Procedure of Preliminary Test

- The equipment was set up as per the test configuration to simulate typical usage per the user's manual. When the EUT is a tabletop system, a wooden turntable with a height of 0.8 meters is used which is placed on the ground plane. When the EUT is a floor-standing equipment, it is placed on the ground plane which has a 3-12 mm non-conductive covering to insulate the EUT from the ground plane.
- Support equipment, if needed, was placed as per EN 55011.
- All I/O cables were positioned to simulate typical usage as per EN 55011.
- The EUT received AC power source, 230V/50Hz, from the outlet socket under the turntable. All support equipment received power from another socket under the turntable.
- The antenna was placed at 10 meter away from the EUT as stated in EN 55011. The antenna connected to the Spectrum Analyzer via a cable and at times a pre-amplifier would be used.
- The Analyzer / Receiver quickly scanned from 30MHz to 1000MHz. The EUT test program was started. Emissions were scanned and measured rotating the EUT to 360 degrees and positioning the antenna 1 to 4 meters above the ground plane, in both the vertical and the horizontal polarization, to maximize the emission reading level.
- The test mode(s) described in Item 3.2 were scanned during the preliminary test:
- After the preliminary scan, we found the test mode described in Item 3.2 producing the highest emission level.
- The EUT and cable configuration, antenna position, polarization and turntable position of the above highest emission level were recorded for the final test.

Procedure of Final Test

- EUT and support equipment were set up on the turntable as per the configuration with highest emission level in the preliminary test.
- The Analyzer / Receiver scanned from 30MHz to 1000MHz. Emissions were scanned and measured rotating the EUT to 360 degrees, varying cable placement and positioning the antenna 1 to 4 meters above the ground plane, in both the vertical and the horizontal polarization, to maximize the emission reading level.
- Recorded at least the six highest emissions. Emission frequency, amplitude, antenna position, polarization and turntable position were recorded into a computer in which correction factors were used to calculate the emission level and compare reading to the applicable limit and only Q.P. reading is presented.
- The test data of the worst-case condition(s) was recorded.

**Data Sample:**

Freq. MHz	Amptd dBuV/m	Margin dB	Limit dBuV/m	Reading dBuV	Factor dB/m	Reading Type (P/Q/A)	Pol. (H/V)
x.xx	26.2	-13.8	40	14	12.2	Q	H

- Freq. = Emission frequency in MHz
Reading = Uncorrected Analyzer/Receiver reading
Factor = Antenna Factor + Cable Loss + Attenuator (3/6/10dB) – Amplifier Gain
Amptd = Uncorrected Analyzer/Receiver reading + Factor
Limit = Limit stated in standard
Margin = Reading in reference to limit
P = Peak Reading
Q = Quasi-peak Reading
A = Average Reading
H = Antenna Polarization: Horizontal
V = Antenna Polarization: Vertical

Calculation Formula

$$\text{Margin (dB)} = \text{Amptd (dBuV/m)} - \text{Limit (dBuV/m)}$$



7.5 TEST RESULTS

Line Conducted Emission

Model: N/A

Test Mode: N/A

Temperature: N/A

Humidity: N/A

Test Results: N/A

Tested by: N/A

Six Highest Conducted Emission Readings							
Frequency Range Investigated				150 kHz to 30 MHz			
Freq (MHz)	Read Level (dBuV)	Factor (dB)	Level (dBuV)	Limit Line (dBuV)	Over Limit (dB)	Reading Type (P/Q/A)	Line (L1/L2)

NOTE: The subject equipment is not intended to be connected to AC mains supply. Therefore, this test is not applicable.

Common Mode Conducted Emission

Not applicable.

**Radiated Emission****Model:** ADAM-4510I**Test Mode:** Mode 1**Temperature:** 28°C**Humidity:** 75% RH**Test Results:** Passed**Tested by:** Benson Yang

(The chart below shows the highest readings taken from the final data.)

Six Highest Radiated Emission Readings							
Frequency Range Investigated				30 MHz to 1000 MHz at 10m			
Freq (MHz)	Amptd (dBuV/m)	Margin (dB)	Limit (dBuV/m)	Reading (dBuV)	Factor (dB/m)	Reading Type (P/Q/A)	Pol. (H/V)
79.8200	32.36	-7.64	40.00	52.00	-19.64	Q	V
172.5600	32.01	-7.99	40.00	47.90	-15.89	Q	V
66.4100	31.94	-8.06	40.00	52.70	-20.76	Q	H
79.3300	33.42	-6.58	40.00	53.10	-19.68	Q	H
128.9100	32.93	-7.07	40.00	46.80	-13.87	Q	H
183.7900	32.62	-7.38	40.00	48.70	-16.08	Q	H

NOTE: None.



8 POWER HARMONICS TEST

Port : DC Power Port
Basic Standard : EN 61000-3-2 (2000)
Limits : CLASS A ; CLASS D
Tested by : N/A
Temperature : N/A
Humidity : N/A

Limit:

Limits for Class A equipment	
Harmonics Order n	Max. permissible harmonics current A
Odd harmonics	
3	2.30
5	1.14
7	0.77
9	0.40
11	0.33
13	0.21
15<=n<=39	0.15x15/n
Even harmonics	
2	1.08
4	0.43
6	0.30
8<=n<=40	0.23x8/n

Limits for Class D equipment		
Harmonics Order n	Max. permissible harmonics current per watt mA/W	Max. permissible harmonics current A
Odd Harmonics only		
3	3.4	2.30
5	1.9	1.14
7	1.0	0.77
9	0.5	0.40
11	0.35	0.33
13	0.30	0.21
15<=n<=39	3.85/n	0.15x15/n

Block Diagram of Test Setup:

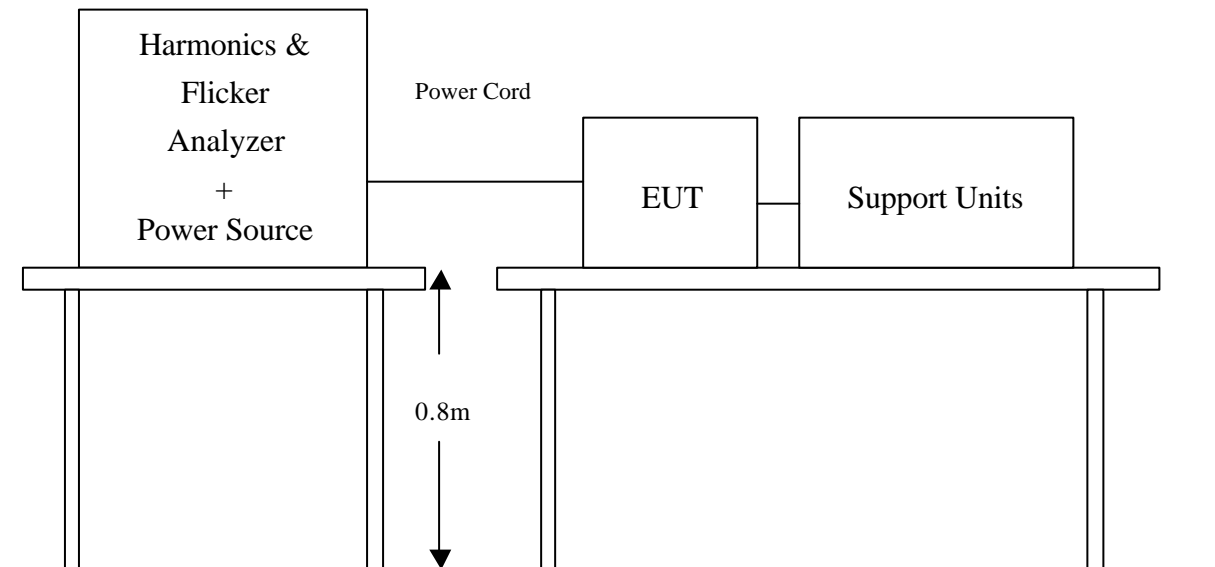

Test Procedure:

- a. The EUT was placed on the top of a wooden table 0.8 meters above the ground and operated to produce the maximum harmonic components under normal operating conditions for each successive harmonic component in turn.
- b. The correspondent test program of test instrument to measure the current harmonics emanated from EUT is chosen. The measure time shall be not less than the time necessary for the EUT to be exercised.

Test Result :

PASS **FAIL**

Note: The subject equipment is not intended to be connected to AC mains supply. Therefore, this test is not applicable.

9 POWER VOLTAGE FLUCTUATION / FLICKER TEST

Port : DC Power Port
Basic Standard : EN 61000-3-3 (1995 + A1: 2001)
Limits : § of EN 61000-3-3
Tested by : N/A
Temperature : N/A
Humidity : N/A

Limit:

TEST ITEM	LIMIT	REMARK
P_{st}	1.0	P_{st} means short-term flicker indicator.
P_{lt}	0.65	P_{lt} means long-term flicker indicator.
T_{dt} (ms)	500	T_{dt} means maximum time that dt exceeds 3.3 %.
d_{max} (%)	4%	d_{max} means maximum relative voltage change.
dc (%)	3.3%	dc means relative steady-state voltage change

Block Diagram of Test Setup:

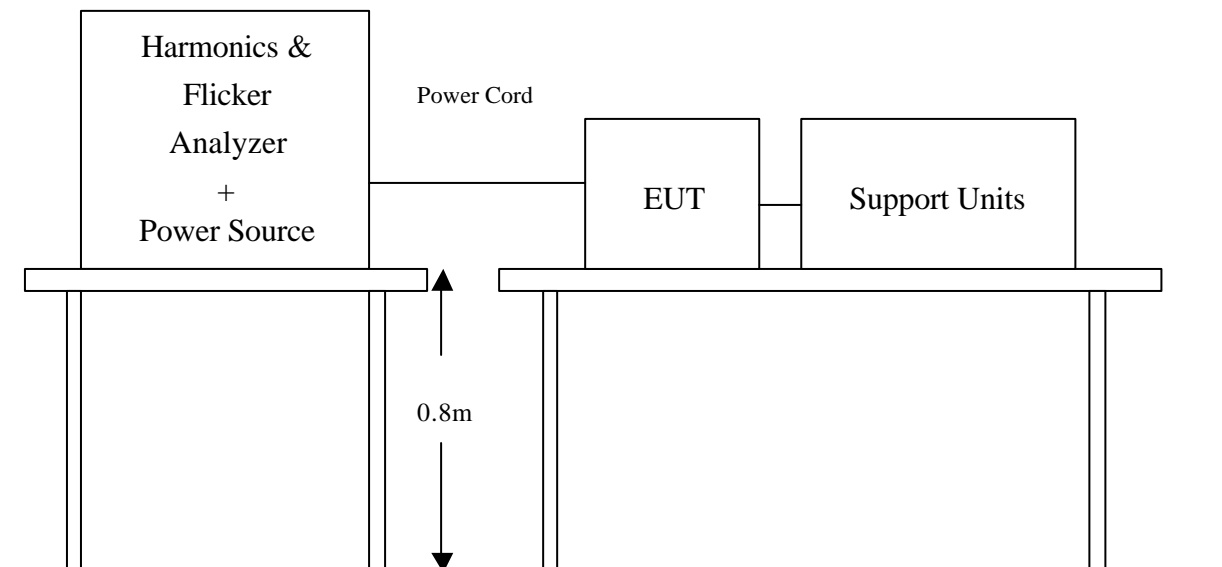

**Test Procedure:**

- a. The EUT was placed on the top of a wooden table 0.8 meters above the ground and operated to produce the most unfavorable sequence of voltage changes under normal operating conditions.
- b. During the flick measurement, the measure time shall include that part of whole operation cycle in which the EUT produce the most unfavorable sequence of voltage changes. The observation period for short-term flicker indicator is 10 minutes and the observation period for long-term flicker indicator is 2 hours.

Test Result:

TEST PARAMETER	MEASUREMENT VALUE	LIMIT	RESULT
P_{st}	N/A	1.0	N/A
P_{It}	N/A	0.65	N/A
T_{dt} (ms)	N/A	500	N/A
d_{max} (%)	N/A	4%	N/A
dc (%)	N/A	3.3%	N/A

Note: The subject equipment is not intended to be connected to AC mains supply. Therefore, this test is not applicable.

10 ELECTROSTATIC DISCHARGE (ESD) IMMUNITY TEST

10.1 EN 55024

Port	: Enclosure
Basic Standard	: IEC/EN 61000-4-2
Test Level	: ± 8 kV (Air Discharge) ± 4 kV (Contact Discharge) ± 4 kV (Indirect Discharge)
Performance Criterion:	B (Standard Required)
Tested by	: Benson Yang
Temperature	: 20°C
Humidity	: 55%
Pressure	: 1010mbar

Block Diagram of Test Setup:

(The 470 k ohm resistors are installed per standard requirement.)

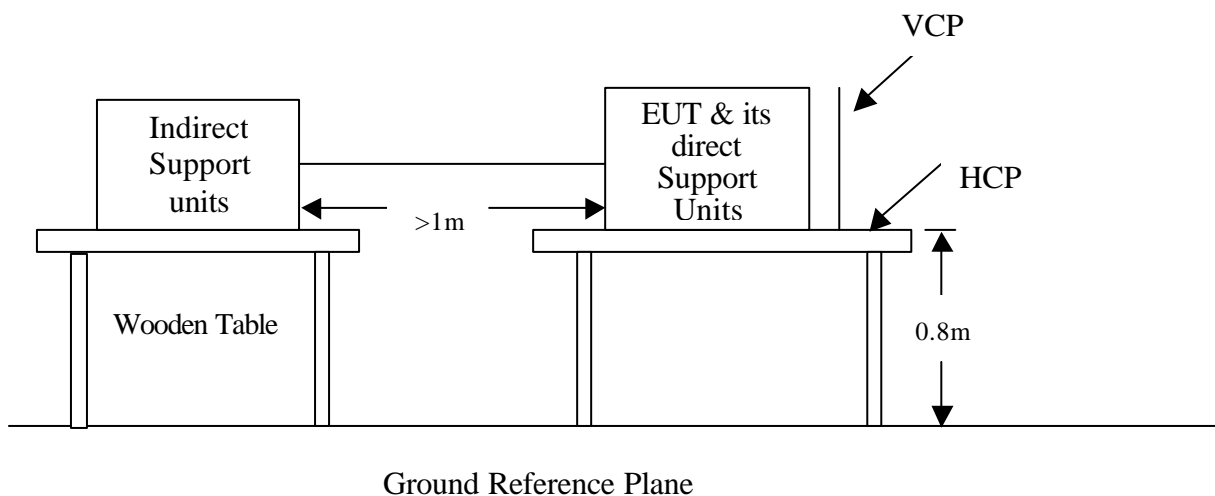



Test Procedure:

1. The EUT was located 0.1 m minimum from all sides of the HCP.
2. The indirect support units were located 1 m minimum away from the EUT, but direct support unit was/were located at same location as EUT on the HCP and keep at a distance of 10 cm with EUT.
3. As per the requirement of EN 55024; applying direct contact discharge at the sides other than front of EUT at minimum 50 discharges (25 positive and 25 negative) if applicable, can't be applied direct contact discharge side of EUT then the indirect discharge shall be applied. One of the test points shall be subjected to at least 50 indirect discharge (contact) to the front edge of horizontal coupling plane.
4. Other parts of EUT where it is not possible to perform contact discharge then selecting appropriate points of EUT for air discharge, a minimum of 10 single air discharges shall be applied.
5. The application of ESD to the contact of open connectors is not required.
6. The EUT direct connection units also need to be applied ESD at the port of EUT cable connected.
7. Putting a mark on EUT to show tested points. The following test condition was followed during the tests.

Note: As per IEC/EN 61000-4-2, two 470k bleed resistors cable is connected between the EUT and HCP during the test applicable for power ungrounded or battery operating unit only.

The electrostatic discharges were applied as follows:

Amount of discharge	Voltage	Coupling	Result (Pass/Fail)
Min. 10 /Point	± 8 kV	Air Discharge	Pass
Min. 25 /Point	± 4 kV	Contact Discharge	Pass
Min. 25 /Point	± 4 kV	Indirect Discharge HCP (Front)	Pass
Min. 25 /Point	± 4 kV	Indirect Discharge VCP (Right)	Pass
Min. 25 /Point	± 4 kV	Indirect Discharge VCP (Left)	Pass
Min. 25 /Point	± 4 kV	Indirect Discharge VCP (Back)	Pass

****For the tested points to EUT, please refer to attached page.
(Blue arrow mark for contact discharge and red arrow mark for air discharge)**



Performance & Result:

- Criterion A:** The apparatus continues to operate as intended. No degradation of performance or loss of function is allowed below a performance level specified by the manufacturer, when the apparatus is used as intended. In some cases the performance level may be replaced by a permissible loss of performance.

- Criterion B:** The apparatus continues to operate as intended after the test. No degradation of performance or loss of function is allowed below a performance level specified by the manufacturer, when the apparatus is used as intended. In some cases the performance level may be replaced by a permissible loss of performance. During the test, degradation of performance is however allowed.

- Criterion C:** Temporary loss of function is allowed, provided the functions self recoverable or can be restored by the operation of controls.

PASS **FAIL**

Observation: No function degraded during the tests.

10.2 EN 61000-6-2

Port	: Enclosure
Basic Standard	: IEC/EN 61000-4-2
Test Level	: ± 8 kV (Air Discharge) ± 4 kV (Contact Discharge) ± 4 kV (Indirect Discharge)
Performance Criterion:	B (Standard Required)
Tested by	: Benson Yang
Temperature	: 20°C
Humidity	: 55%
Pressure	: 1010mbar

Block Diagram of Test Setup:

(The 470 k ohm resistors are installed per standard requirement.)

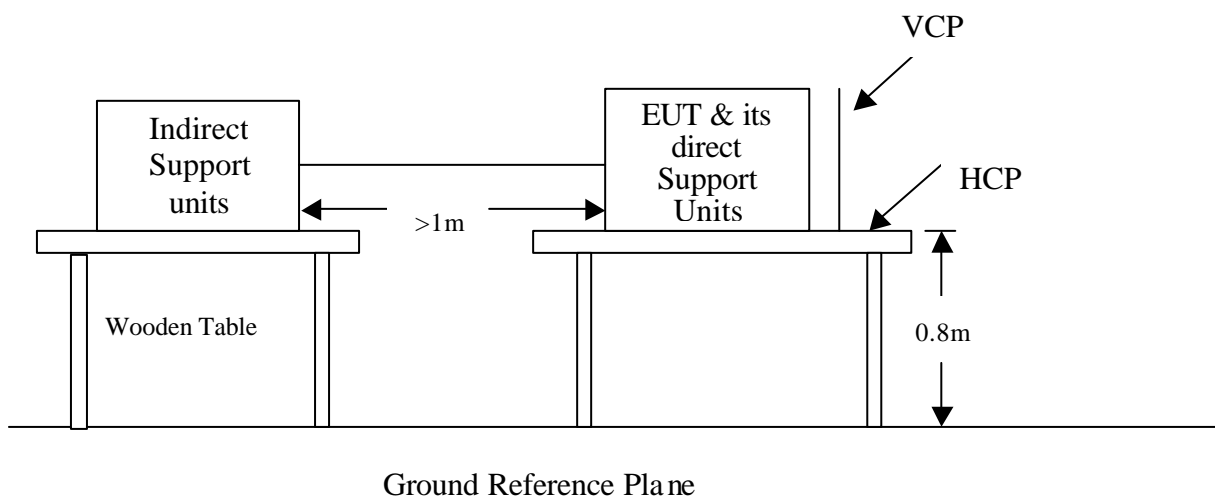

**Test Procedure:**

1. The EUT was located 0.1 m minimum from all sides of the HCP.
2. The indirect support units were located 1 m minimum away from the EUT, but direct support unit was/were located at same location as EUT on the HCP and keep at a distance of 10 cm with EUT.
3. A scroll 'H' test program was loaded and executed in Windows XP mode.
4. The EUT sent above message to LCD Panel of Notebook PC at remote side and related peripherals through the test.
5. Active the communication function if the EUT with such port(s).
6. As per the requirement of IEC 61000-4-2; applying direct contact discharge each point at minimum 20 discharges (10 positive and 10 negative) if applicable, for the points can't be applied direct contact discharge then the indirect discharge shall be applied. One of the test points shall be subjected to at least 20 indirect discharge (contact) to the front edge of horizontal coupling plane and each side of EUT via vertical coupling plane .
7. Other parts of EUT where it is not possible to perform contact discharge then selecting appropriate points of EUT for air discharge, a minimum of 20 single air discharges shall be applied.
8. The application of ESD to the contact of open connectors is not required.
9. The EUT direct connection units also need to be applied ESD at the port of EUT cable connected.
10. Putting a mark on EUT to show tested points. The following test condition was followed during the tests.

Note: As per EN 61000-4-2, two 470k bleed resistors cable is connected between the EUT and HCP during the test applicable for power ungrounded or battery operating unit only.

The electrostatic discharges were applied as follows:

Amount of discharge	Voltage	Coupling	Result (Pass/Fail)
Min. 10 /Point	± 8 kV	Air Discharge	Pass
Min. 10 /Point	± 4 kV	Contact Discharge	Pass
Min. 10 /Point	± 4 kV	Indirect Discharge HCP (Front)	Pass
Min. 10 /Point	± 4 kV	Indirect Discharge VCP (Right)	Pass
Min. 10 /Point	± 4 kV	Indirect Discharge VCP (Left)	Pass
Min. 10 /Point	± 4 kV	Indirect Discharge VCP (Back)	Pass

****For the tested points to EUT, please refer to attached page.**

(Blue arrow mark for contact discharge and red arrow mark for air discharge)



Performance & Result:

- Criterion A:** The apparatus continues to operate as intended. No degradation of performance or loss of function is allowed below a performance level specified by the manufacturer, when the apparatus is used as intended. In some cases the performance level may be replaced by a permissible loss of performance.

- Criterion B:** The apparatus continues to operate as intended after the test. No degradation of performance or loss of function is allowed below a performance level specified by the manufacturer, when the apparatus is used as intended. In some cases the performance level may be replaced by a permissible loss of performance. During the test, degradation of performance is however allowed.

- Criterion C:** Temporary loss of function is allowed, provided the functions self recoverable or can be restored by the operation of controls.

PASS **FAIL**

Observation: No function degraded during the tests.

The Tested Points of EUT

Photo 1 of 2

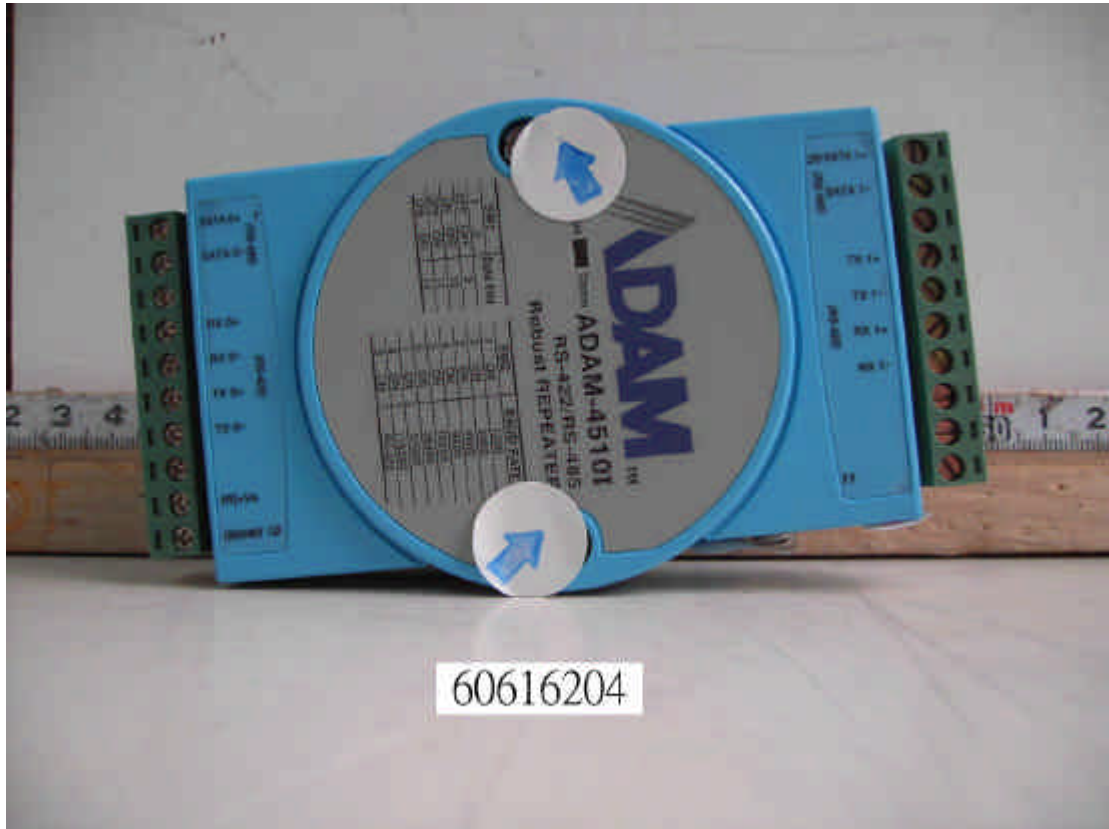
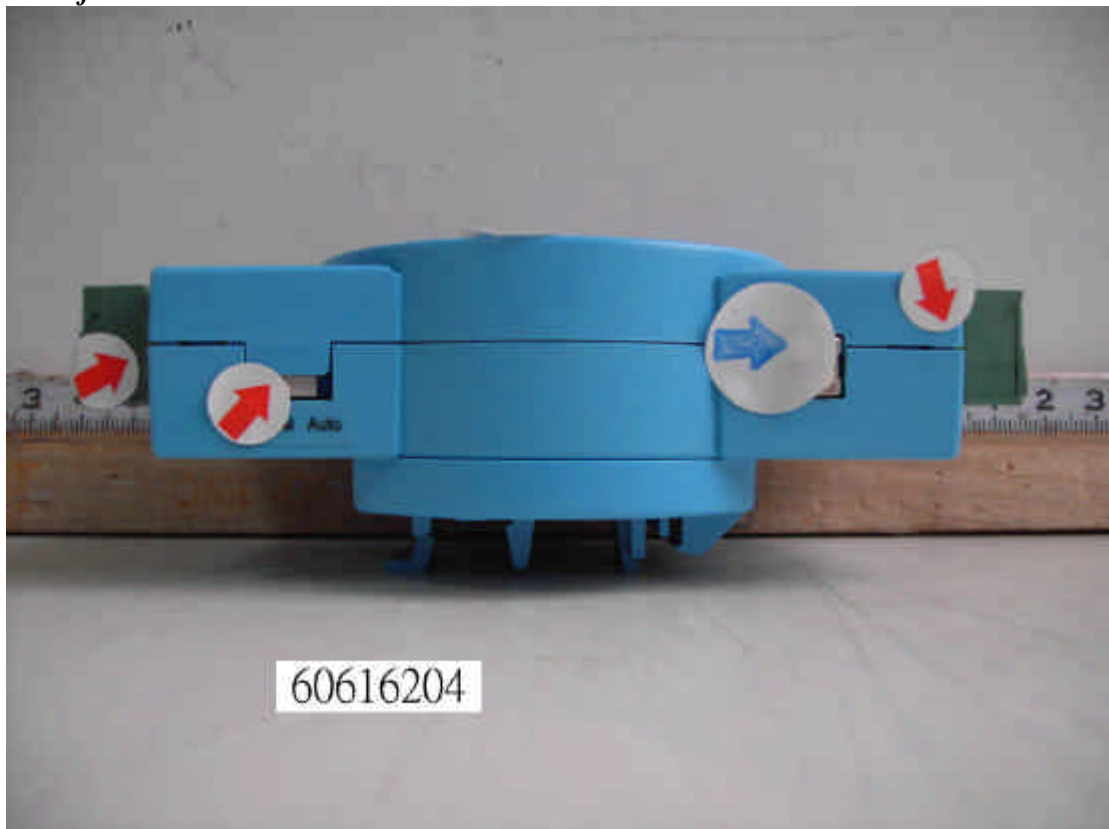

Photo 2 of 2



11 RADIATED ELECTROMAGNETIC FIELD IMMUNITY TEST

11.1 EN 55024

Port	: Enclosure
Basic Standard	: IEC/EN 61000-4-3
Requirements	: 3 V/m / with 80% AM. 1kHz Modulation.
Performance Criterion:	A (Standard Required)
Tested by	: Benson Yang
Temperature	: 20°C
Humidity	: 55%
Pressure	: 1010mbar

Block Diagram of Test Setup:

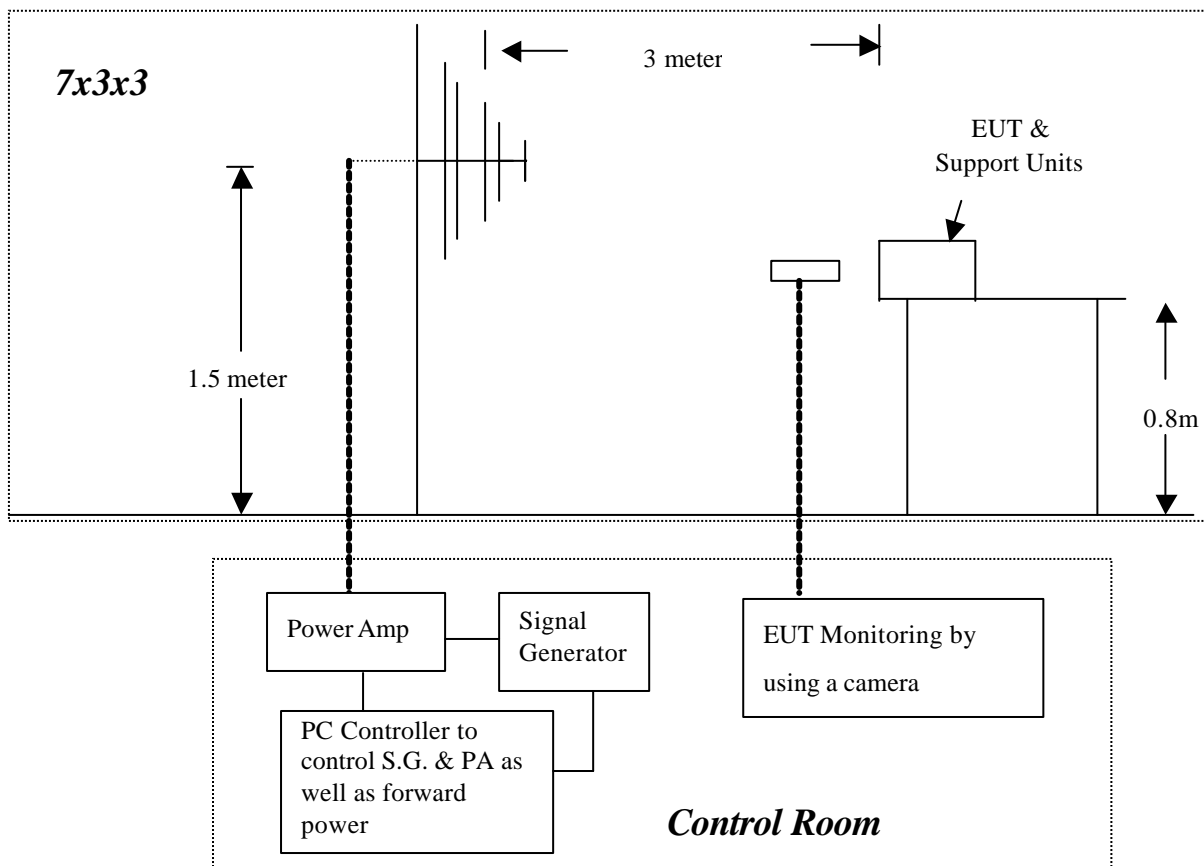

**Test Procedure:**

1. The EUT and support units were located at the edge of supporting table keep 3 meter away from transmitting antenna, it just the calibrated square area of field uniformity.
2. Adjusting the cables to be exposed to the electromagnetic field as possible.
3. Performing a Radiated Emission Scan in range of 80 to 1000 MHz prior to do RS test and records the more higher emission frequencies for the reference of RS test, due to antenna effectiveness.
4. Adjusting the monitoring camera to monitor the “H” message as clear as possible.
5. Setting the testing parameters of RS test software per IEC 61000-4-3.
6. Referring to the tested data of step 3 to performing the RS test from 80 to 1000 MHz.
7. Recording the test result in following table.
8. Changing the EUT to the other side and repeat step 3 to 6, until 4 sides of EUT were verified.

IEC 61000-4-3 Final test conditions:

Test level : 3V/m
Steps : 1 % of fundamental
Dwell Time : 3 sec

Range (MHz)	Field	Modulation	Polarity	Position (°)	Result (Pass/Fail)
80-1000	3V/m	Yes	H	Front	Pass
80-1000	3V/m	Yes	V	Front	Pass
80-1000	3V/m	Yes	H	Right	Pass
80-1000	3V/m	Yes	V	Right	Pass
80-1000	3V/m	Yes	H	Back	Pass
80-1000	3V/m	Yes	V	Back	Pass
80-1000	3V/m	Yes	H	Left	Pass
80-1000	3V/m	Yes	V	Left	Pass



Performance & Result:

- Criterion A:** The apparatus continues to operate as intended. No degradation of performance or loss of function is allowed below a performance level specified by the manufacturer, when the apparatus is used as intended. In some cases the performance level may be replaced by a permissible loss of performance.

- Criterion B:** The apparatus continues to operate as intended after the test. No degradation of performance or loss of function is allowed below a performance level specified by the manufacturer, when the apparatus is used as intended. In some cases the performance level may be replaced by a permissible loss of performance. During the test, degradation of performance is however allowed.

- Criterion C:** Temporary loss of function is allowed, provided the functions self recoverable or can be restored by the operation of controls.

<input checked="" type="checkbox"/> PASS <input type="checkbox"/> FAIL
Observation: No function degraded during the tests.

11.2 EN 61000-6-2

Port	: Enclosure
Basic Standard	: IEC/EN 61000-4-3
Requirements	: 10 V/m / with 80% AM. 1kHz Modulation.
Performance Criterion:	A (Standard Required)
Tested by	: Benson Yang
Temperature	: 20°C
Humidity	: 55%
Pressure	: 1010mbar

Block Diagram of Test Setup:

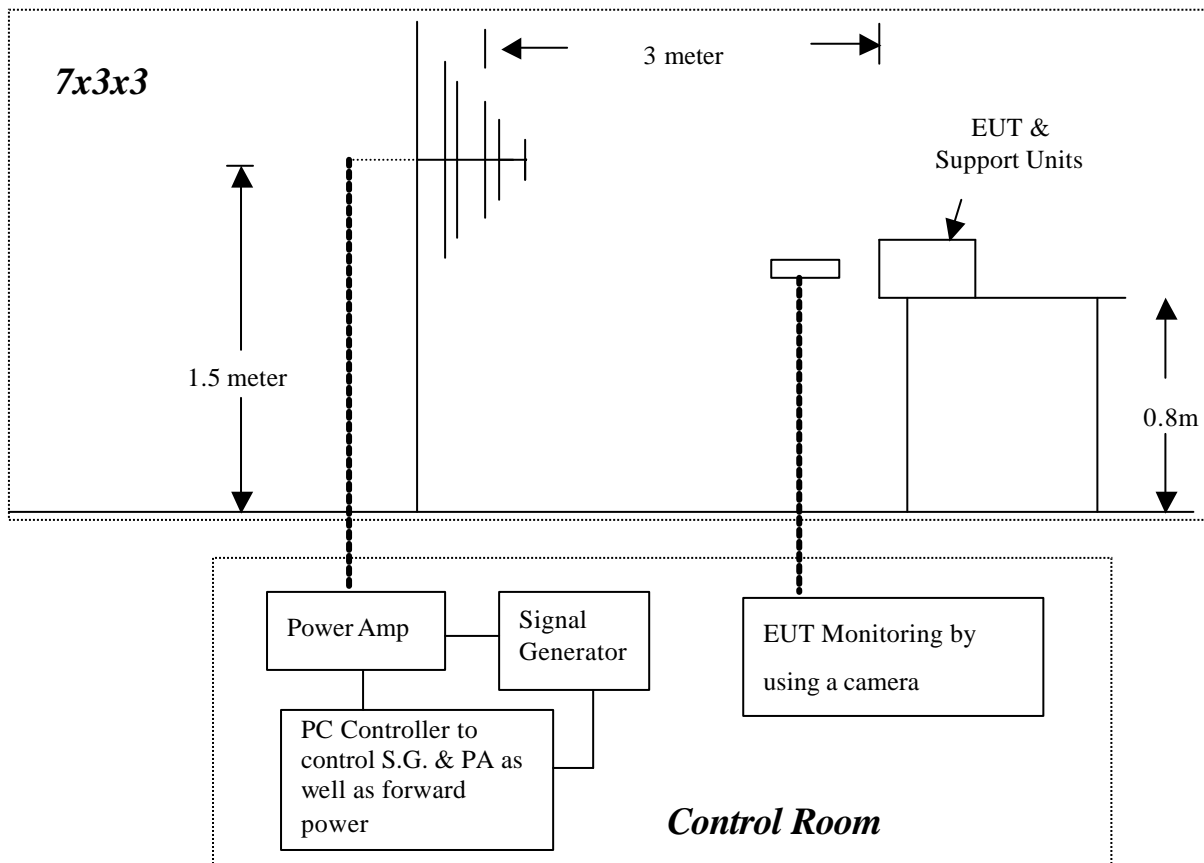

**Test Procedure:**

1. The EUT was located at the edge of supporting table keep 3 meter away from transmitting antenna, it just the calibrated square area of field uniformity. The support units were located outside of the uniformity area, but the cable(s) connected with EUT were exposed to the calibrated field as per IEC/EN 61000-4-3.
2. Set the testing parameters of RS test software per IEC/EN 61000-4-3.
3. From the result of pre-test in step 3, choice the worst side of EUT for final test from 80 MHz to 1000 MHz at 1% steps.
4. Recorded the test result in following table.

Final test conditions:

Test level : 10V/m
Steps : 1 % of fundamental
Dwell Time : 3 sec

Range (MHz)	Field	Modulation	Polarity	Position	Result (Pass/Fail)
80-1000	10V/m	Yes	H	Front	Pass
80-1000	10V/m	Yes	V	Front	Pass
80-1000	10V/m	Yes	H	Right	Pass
80-1000	10V/m	Yes	V	Right	Pass
80-1000	10V/m	Yes	H	Back	Pass
80-1000	10V/m	Yes	V	Back	Pass
80-1000	10V/m	Yes	H	Left	Pass
80-1000	10V/m	Yes	V	Left	Pass



Performance & Result:

- Criterion A:** The apparatus continues to operate as intended. No degradation of performance or loss of function is allowed below a performance level specified by the manufacturer, when the apparatus is used as intended. In some cases the performance level may be replaced by a permissible loss of performance.
- Criterion B:** The apparatus continues to operate as intended after the test. No degradation of performance or loss of function is allowed below a performance level specified by the manufacturer, when the apparatus is used as intended. In some cases the performance level may be replaced by a permissible loss of performance. During the test, degradation of performance is however allowed.
- Criterion C:** Temporary loss of function is allowed, provided the functions self recoverable or can be restored by the operation of controls.

PASS **FAIL**

Observation: No function degraded during the tests.

12 FAST TRANSIENTS/BURST IMMUNITY TEST

12.1 EN 55024

Port	: DC Power Port
Basic Standard	: IEC/EN 61000-4-4
Requirements	: ± 0.5 kV for DC Power Port
Performance Criteria	: B (Standard Required)
Tested by	: Benson Yang
Temperature	: 20°C
Humidity	: 55%
Pressure	: 1010mbar

Block Diagram of Test Setup:

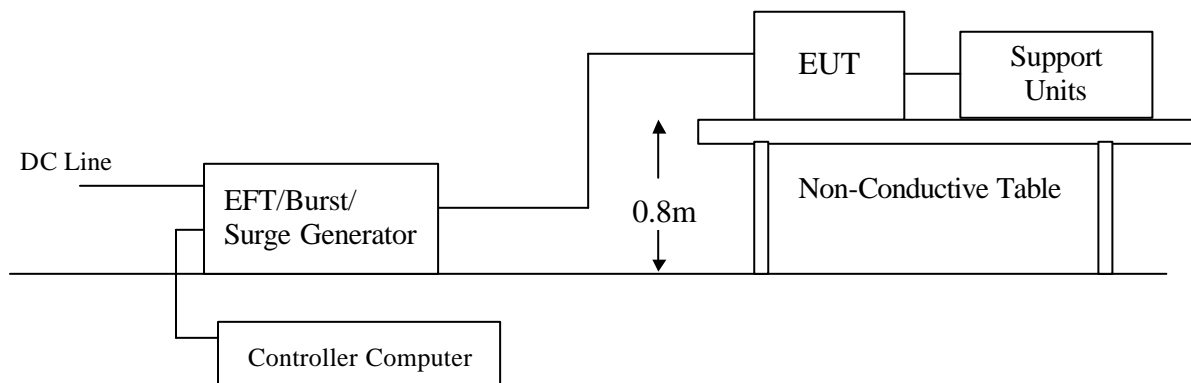

Test Procedure:

1. The EUT and support units were located on a wooden table 0.8 m away from ground reference plane.
2. A 1.0 meter long power cord was attached to EUT during the test.
3. The length of communication cable between communication port and clamp was keeping within 1 meter.
4. Injected test voltage to the EUT ports from minimum to standard request or client request.
5. Recorded the test result as shown in following table.

**Test conditions:**

Impulse Frequency : 5kHz
 Tr/Th : 5/50ns
 Burst Duration : 15ms
 Burst Period : 300ms

Inject Line	Voltage kV	Inject Method	Result (Pass/Fail)
L	± 0.5	Direct	Pass
N	± 0.5	Direct	Pass
L + N	± 0.5	Direct	Pass

Performance & Result:

- Criterion A:** The apparatus continues to operate as intended. No degradation of performance or loss of function is allowed below a performance level specified by the manufacturer, when the apparatus is used as intended. In some cases the performance level may be replaced by a permissible loss of performance.
- Criterion B:** The apparatus continues to operate as intended after the test. No degradation of performance or loss of function is allowed below a performance level specified by the manufacturer, when the apparatus is used as intended. In some cases the performance level may be replaced by a permissible loss of performance. During the test, degradation of performance is however allowed.
- Criterion C:** Temporary loss of function is allowed, provided the functions self recoverable or can be restored by the operation of controls.

PASS **FAIL**

Observation: No function degraded during the tests.

12.2 EN 61000-6-2

Port	: DC Power Port
Basic Standard	: IEC/EN 61000-4-4
Requirements	: ± 2 kV for DC Power Port
Performance Criteria	: B (Standard Required)
Tested by	: Benson Yang
Temperature	: 20°C
Humidity	: 55%
Pressure	: 1010mbar

Block Diagram of Test Setup:

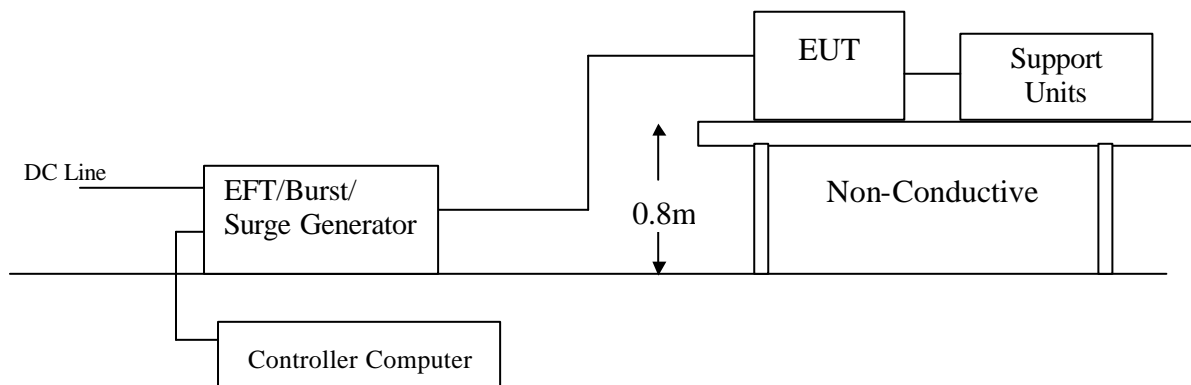

Test Procedure:

1. The EUT and support units were located on a wooden table 0.8 m away from ground reference plane.
2. A 1.0 meter long power cord was attached to EUT during the test.
3. The length of communication cable between communication port and clamp was keeping within 1 meter.
4. Injected test voltage to the EUT ports from minimum to standard request or client request.
5. Recorded the test result as shown in following table.



Test conditions:

Impulse Frequency : 5kHz
Tr/Th : 5/50ns
Burst Duration : 15ms
Burst Period : 300ms

Inject Line	Voltage kV	Inject Method	Result (Pass/Fail)
L	± 2	Direct	Pass
N	± 2	Direct	Pass
L + N	± 2	Direct	Pass

Performance & Result:

- Criterion A:** The apparatus continues to operate as intended. No degradation of performance or loss of function is allowed below a performance level specified by the manufacturer, when the apparatus is used as intended. In some cases the performance level may be replaced by a permissible loss of performance.
- Criterion B:** The apparatus continues to operate as intended after the test. No degradation of performance or loss of function is allowed below a performance level specified by the manufacturer, when the apparatus is used as intended. In some cases the performance level may be replaced by a permissible loss of performance. During the test, degradation of performance is however allowed.
- Criterion C:** Temporary loss of function is allowed, provided the functions self recoverable or can be restored by the operation of controls.

<input checked="" type="checkbox"/> PASS <input type="checkbox"/> FAIL
Observation: No function degraded during the tests.

13 SURGE IMMUNITY TEST

13.1 EN 55024

Port	: DC Power Port
Basic Standard	: IEC/EN 61000-4-5
Requirements	: ± 0.5 kV (Line to Line) for DC Power Port
Performance Criteria	: B (Standard Required)
Tested by	: Benson Yang
Temperature	: 20°C
Humidity	: 55%
Pressure	: 1010mbar

Block Diagram of Test Setup:

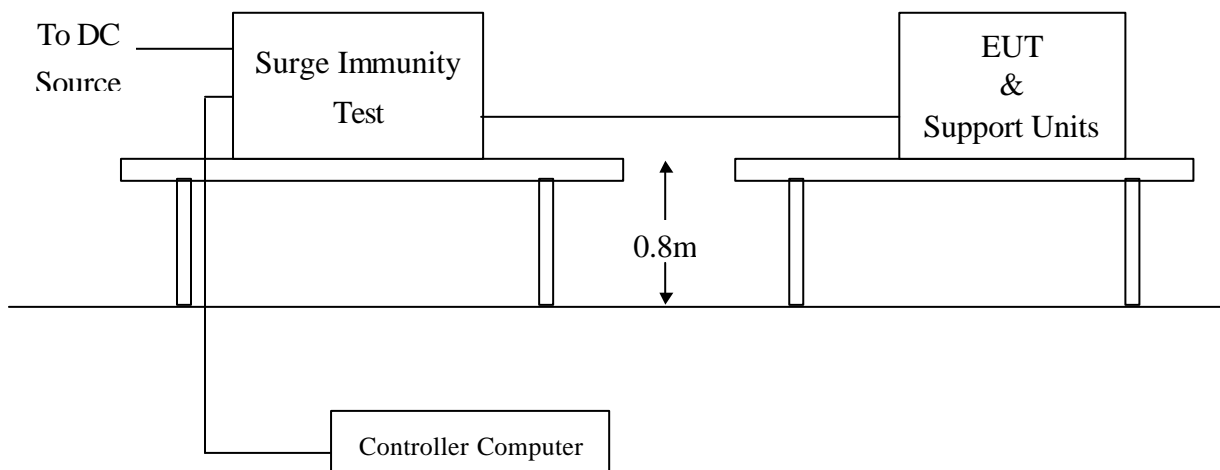

Test Procedure:

1. The EUT and support units were located on a wooden table 0.8 m away from ground floor.
2. Injected test voltage to the EUT ports from minimum to standard request or client request.
3. Recorded the test result as shown in following table.

**Test conditions:**

Voltage Waveform : 1.2/50 *us*
 Current Waveform : 8/20 *us*
 Polarity : Positive/Negative
 Number of Test : 5

Coupling Line	Voltage (kV)	Polarity	Coupling Method	Result (Pass/Fail)
L1-L2	0.5	Positive	Capacitive	Pass
L1-L2	0.5	Negative	Capacitive	Pass

Performance & Result:

- Criterion A:** The apparatus continues to operate as intended. No degradation of performance or loss of function is allowed below a performance level specified by the manufacturer, when the apparatus is used as intended. In some cases the performance level may be replaced by a permissible loss of performance.
- Criterion B:** The apparatus continues to operate as intended after the test. No degradation of performance or loss of function is allowed below a performance level specified by the manufacturer, when the apparatus is used as intended. In some cases the performance level may be replaced by a permissible loss of performance. During the test, degradation of performance is however allowed.
- Criterion C:** Temporary loss of function is allowed, provided the functions self recoverable or can be restored by the operation of controls.

PASS **FAIL**

Observation: No function degraded during the tests.

13.2 EN 61000-6-2

Port	: DC Power Port
Basic Standard	: IEC/EN 61000-4-5
Requirements	: ± 0.5 kV (Line to Line) for DC Power Port
Performance Criteria	: B (Standard Required)
Tested by	: Benson Yang
Temperature	: 20°C
Humidity	: 55%
Pressure	: 1010mbar

Block Diagram of Test Setup:

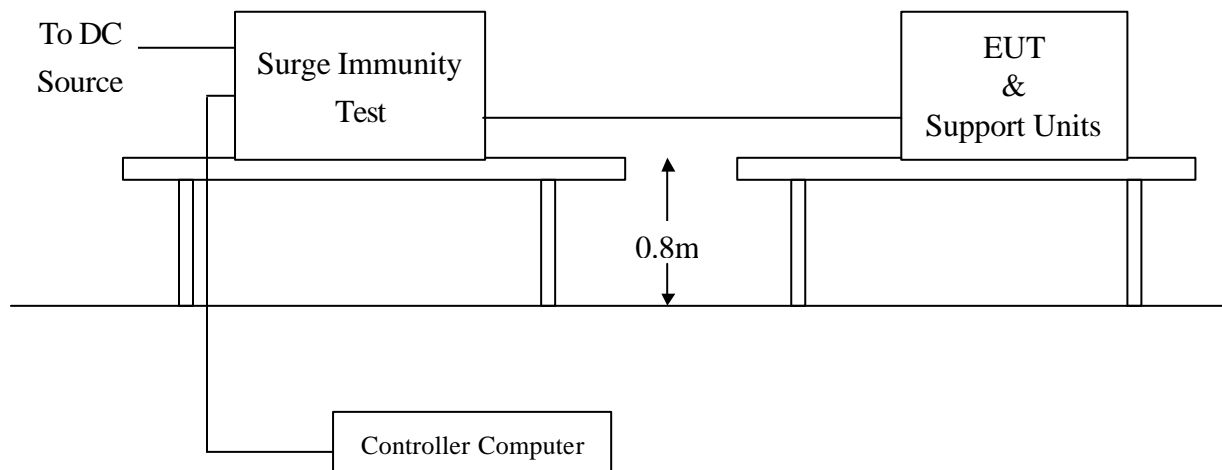

Test Procedure:

1. The EUT and support units were located on a wooden table 0.8 m away from ground floor.
2. Injected test voltage to the EUT ports from minimum to standard request or client request.
3. Recorded the test result as shown in following table.

**Test conditions:**

Voltage Waveform : 1.2/50 *us*
 Current Waveform : 8/20 *us*
 Polarity : Positive/Negative
 Number of Test : 5

Coupling Line	Voltage (kV)	Polarity	Coupling Method	Result (Pass/Fail)
L1-L2	0.5	Positive	Capacitive	Pass
L1-L2	0.5	Negative	Capacitive	Pass

Performance & Result:

- Criterion A:** The apparatus continues to operate as intended. No degradation of performance or loss of function is allowed below a performance level specified by the manufacturer, when the apparatus is used as intended. In some cases the performance level may be replaced by a permissible loss of performance.
- Criterion B:** The apparatus continues to operate as intended after the test. No degradation of performance or loss of function is allowed below a performance level specified by the manufacturer, when the apparatus is used as intended. In some cases the performance level may be replaced by a permissible loss of performance. During the test, degradation of performance is however allowed.
- Criterion C:** Temporary loss of function is allowed, provided the functions self recoverable or can be restored by the operation of controls.

PASS **FAIL**

Observation: No function degraded during the tests.

14 CONDUCTED DISTURBANCE/INDUCED RADIO-FREQUENCY FIELD IMMUNITY TEST

14.1 EN 55024

Port	: DC Power Port
Basic Standard	: IEC/EN 61000-4-6
Requirements	: 3V, with 80% AM. 1kHz Modulation.
Injection Method	: CDN-M2 for DC Power Port
Performance Criterion	: A (Standard Required)
Tested by	: Benson Yang
Temperature	: 20°C
Humidity	: 55%
Pressure	: 1010mbar

Block Diagram of Test Setup:

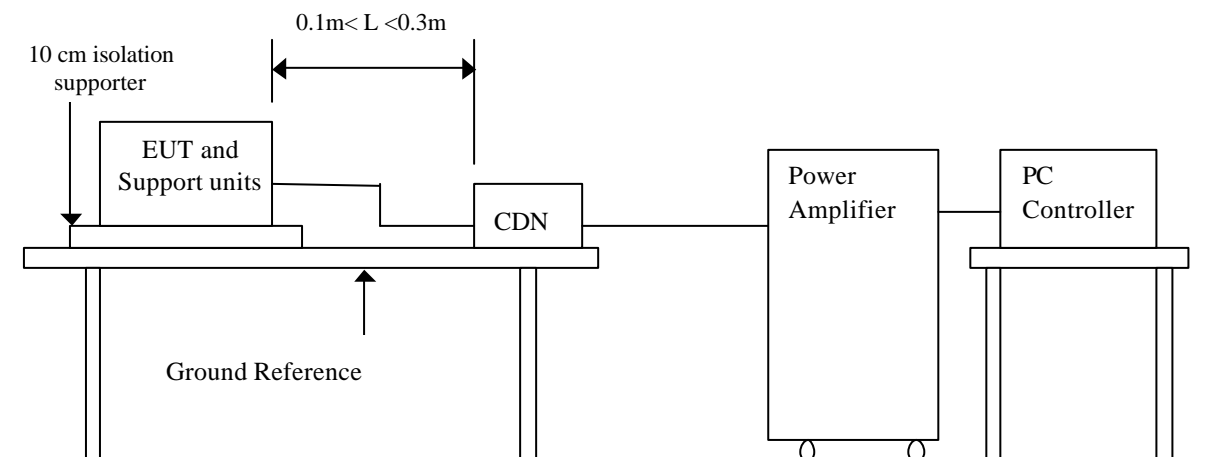

Test Procedure:

1. The EUT and support units were located at a ground reference plane with the interposition of a 0.1 m thickness insulating support and the CDN was located on GRP directly.
2. Set the testing parameters of CS test software as per IEC/EN 61000-4-6.
3. Recorded the test result in following table.

**Test conditions:**

Frequency Range : 0.15MHz-80MHz

Frequency Step : 1% of fundamental

Dwell Time : 3 sec

Range (MHz)	Field	Modulation	Result (Pass/Fail)
0.15-80	3V	Yes	Pass

Performance & Result:

- Criterion A:** The apparatus continues to operate as intended. No degradation of performance or loss of function is allowed below a performance level specified by the manufacturer, when the apparatus is used as intended. In some cases the performance level may be replaced by a permissible loss of performance.
- Criterion B:** The apparatus continues to operate as intended after the test. No degradation of performance or loss of function is allowed below a performance level specified by the manufacturer, when the apparatus is used as intended. In some cases the performance level may be replaced by a permissible loss of performance. During the test, degradation of performance is however allowed.
- Criterion C:** Temporary loss of function is allowed, provided the functions self recoverable or can be restored by the operation of controls.

PASS **FAIL**

Observation: No function degraded during the tests.

14.2 EN 61000-6-2

Port	: DC Power Port
Basic Standard	: IEC/EN 61000-4-6
Requirements	: 10V, with 80% AM. 1kHz Modulation.
Injection Method	: CDN-M2 for DC Power Port
Performance Criterion	: A (Standard Required)
Tested by	: Benson Yang
Temperature	: 20°C
Humidity	: 55%
Pressure	: 1010mbar

Block Diagram of Test Setup:

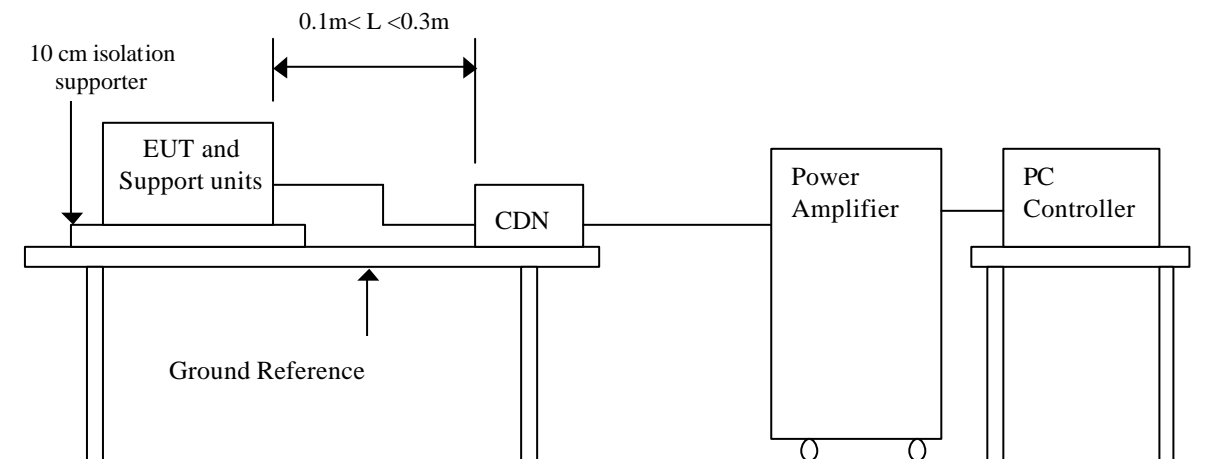

Test Procedure:

1. The EUT and support units were located at a ground reference plane with the interposition of a 0.1 m thickness insulating support and the CDN was located on GRP directly.
2. Set the testing parameters of CS test software as per IEC/EN 61000-4-6.
3. Recorded the test result in following table.



Test conditions:

Frequency Range : 0.15MHz-80MHz

Frequency Step : 1% of fundamental

Dwell Time : 3 sec

Range (MHz)	Field	Modulation	Result (Pass/Fail)
0.15-80	10V	Yes	Pass

Performance & Result:

Criterion A: The apparatus continues to operate as intended. No degradation of performance or loss of function is allowed below a performance level specified by the manufacturer, when the apparatus is used as intended. In some cases the performance level may be replaced by a permissible loss of performance.

Criterion B: The apparatus continues to operate as intended after the test. No degradation of performance or loss of function is allowed below a performance level specified by the manufacturer, when the apparatus is used as intended. In some cases the performance level may be replaced by a permissible loss of performance. During the test, degradation of performance is however allowed.

Criterion C: Temporary loss of function is allowed, provided the functions self recoverable or can be restored by the operation of controls.

<input checked="" type="checkbox"/> PASS <input type="checkbox"/> FAIL
Observation: No function degraded during the tests.

15 POWER FREQUENCY MAGNETIC FIELD IMMUNITY TEST

15.1 EN 55024

Port	: Enclosure
Basic Standard	: IEC/EN 61000-4-8
Requirements	: 1 A/m
Performance Criterion	: A (Standard Required)
Tested by	: N/A
Temperature	: N/A
Humidity	: N/A
Pressure	: N/A

Block Diagram of Test Setup:

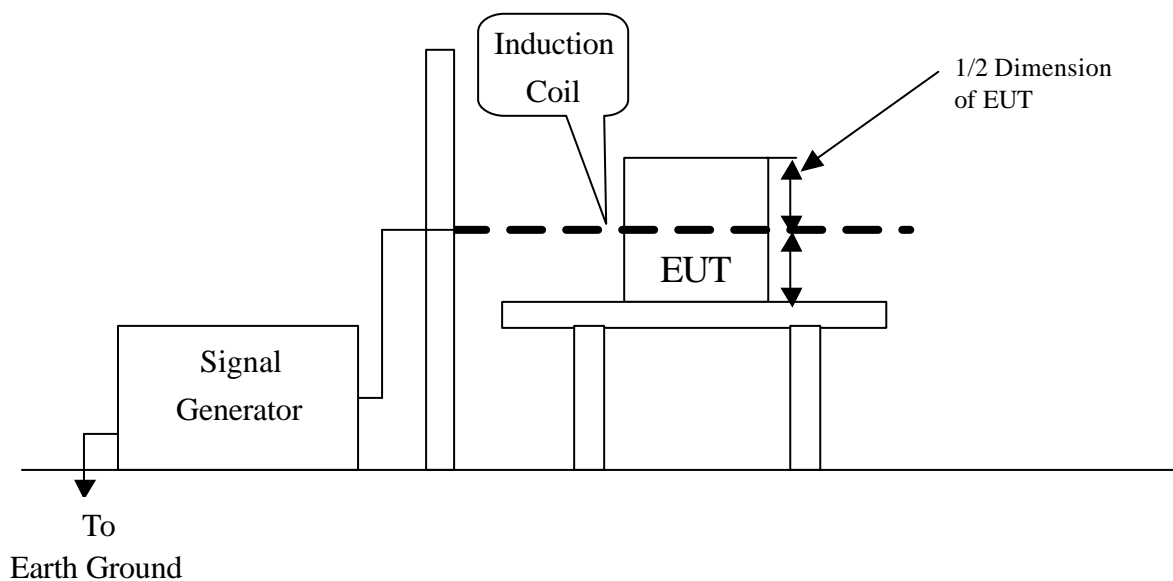

Test Procedure:

1. The EUT and support units were located on Ground Reference Plane with the interposition of a 0.1 m thickness insulation support.
2. Put the induction coil on horizontal direction. (X direction)
3. Recorded the test result as shown in following table.
4. Rotated the induction coil by 90° (Y direction) then repeat step 3.
5. Rotated the induction coil by 90° (Z direction) then repeat step 3.



Test conditions:

Field Strength: 1A/m
Power Freq.: 50Hz
Orientation: X, Y, Z

Orientation	Field	Result (Pass/Fail)	Remark

Performance & Result:

- Criterion A:** The apparatus continues to operate as intended. No degradation of performance or loss of function is allowed below a performance level specified by the manufacturer, when the apparatus is used as intended. In some cases the performance level may be replaced by a permissible loss of performance.
- Criterion B:** The apparatus continues to operate as intended after the test. No degradation of performance or loss of function is allowed below a performance level specified by the manufacturer, when the apparatus is used as intended. In some cases the performance level may be replaced by a permissible loss of performance. During the test, degradation of performance is however allowed.
- Criterion C:** Temporary loss of function is allowed, provided the functions self recoverable or can be restored by the operation of controls.

<input type="checkbox"/> PASS <input type="checkbox"/> FAIL
Observation: The EUT is not containing any component that is susceptible to a 50 Hz or 60 Hz magnetic field. Therefore, this requirement is not applicable to the EUT.

15.2 EN 61000-6-2

Port	: Enclosure
Basic Standard	: IEC/EN 61000-4-8
Requirements	: 30 A/m
Performance Criterion	: A (Standard Required)
Tested by	: Benson Yang
Temperature	: 20°C
Humidity	: 55%
Pressure	: 1010mbar

Block Diagram of Test Setup:

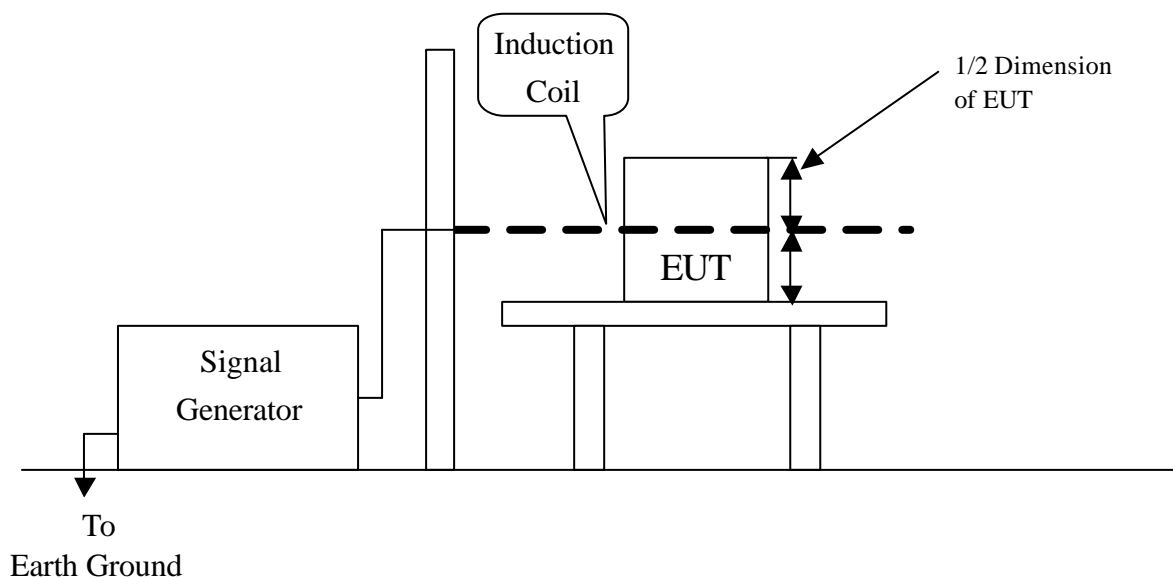

Test Procedure:

1. The EUT and support units were located on Ground Reference Plane with the interposition of a 0.1 m thickness insulation support.
2. Put the induction coil on horizontal direction. (X direction)
3. Recorded the test result as shown in following table.
4. Rotated the induction coil by 90° (Y direction) then repeat step 3.
5. Rotated the induction coil by 90° (Z direction) then repeat step 3.

**Test conditions:**

Field Strength: 30A/m
 Power Freq.: 50Hz, 60Hz
 Orientation: X, Y, Z

Orientation	Field	Result (Pass/Fail)	Remark
X	30A/m, 50Hz	Pass	No function degraded during the tests.
Y	30A/m, 50Hz	Pass	No function degraded during the tests.
Z	30A/m, 50Hz	Pass	No function degraded during the tests.
X	30A/m, 60Hz	Pass	No function degraded during the tests.
Y	30A/m, 60Hz	Pass	No function degraded during the tests.
Z	30A/m, 60Hz	Pass	No function degraded during the tests.

Performance & Result:

- Criterion A:** The apparatus continues to operate as intended. No degradation of performance or loss of function is allowed below a performance level specified by the manufacturer, when the apparatus is used as intended. In some cases the performance level may be replaced by a permissible loss of performance.
- Criterion B:** The apparatus continues to operate as intended after the test. No degradation of performance or loss of function is allowed below a performance level specified by the manufacturer, when the apparatus is used as intended. In some cases the performance level may be replaced by a permissible loss of performance. During the test, degradation of performance is however allowed.
- Criterion C:** Temporary loss of function is allowed, provided the functions self recoverable or can be restored by the operation of controls.

PASS **FAIL**

Observation: No function degraded during the tests.

16 VOLTAGE DIPS / SHORT INTERRUPTIONS

16.1 EN 55024

Port	:	DC Power Port
Basic Standard	:	IEC/EN 61000-4-11
Requirement	:	PHASE ANGLE 0, 45, 90, 135, 180, 225, 270, 315 degrees
Test Interval	:	Min. 10 sec.
Tested by	:	N/A
Temperature	:	N/A
Humidity	:	N/A
Pressure	:	N/A

Voltage Dips	Test Level % U_T	Reduction (%)	Duration (periods)	Performance Criterion
	<5	>95	0.5	B
70	30	25	C	

Voltage Interruptions	Test Level % U_T	Reduction (%)	Duration (periods)	Performance Criterion
	<5	>95	250	C

Block Diagram of Test Setup:

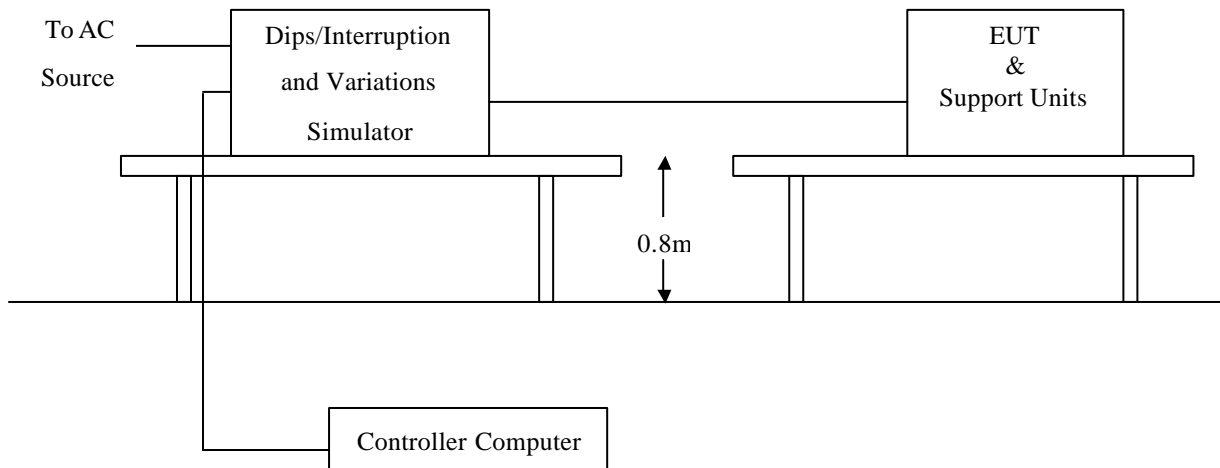

Test Procedure:

1. The EUT and support units were located on a wooden table, 0.8 m away from ground floor.
2. Set the parameter of tests and then Performed the test software of test simulator.
3. Changed Condition to occur at 0 degree crossover point of the voltage waveform.
4. Recorded the test result in test record form.

**Test conditions:**

The duration with a sequence of three dips/interruptions with interval of 10 sec. minimum
(Between each test event)

Voltage Dips:

Test Level % U _T	Reduction (%)	Duration (periods)	Observation	Meet Performance Criterion
0	100	0.5	N/A	N/A
70	30	25	N/A	N/A

Voltage Interruptions:

Test Level % U _T	Reduction (%)	Duration (periods)	Observation	Meet Performance Criterion
0	100	250	N/A	N/A

Note: “Normal” means no any functions degrade during and after the test.

Performance & Result:

Criterion A: The apparatus continues to operate as intended. No degradation of performance or loss of function is allowed below a performance level specified by the manufacturer, when the apparatus is used as intended. In some cases the performance level may be replaced by a permissible loss of performance.

Criterion B: The apparatus continues to operate as intended after the test. No degradation of performance or loss of function is allowed below a performance level specified by the manufacturer, when the apparatus is used as intended. In some cases the performance level may be replaced by a permissible loss of performance. During the test, degradation of performance is however allowed.

Criterion C: Temporary loss of function is allowed, provided the functions self recoverable or can be restored by the operation of controls.

PASS **FAIL**

Observation: The subject equipment is not intended to be connected to AC mains supply. Therefore, this test is not applicable.

16.2 EN 61000-6-2

Port	:	AC Power Port
Basic Standard	:	IEC/EN 61000-4-11
Requirement	:	PHASE ANGLE 0, 45, 90, 135, 180, 225, 270, 315 degrees
Test Interval	:	Min. 10 sec.
Tested by	:	N/A
Temperature	:	N/A
Humidity	:	N/A
Pressure	:	N/A

Test Level % U_T	Reduction (%)	Duration (Periods)	Performance Criteria
70	30	0.5	B
40	60	5	B
40	60	50	C
< 5	> 95	250	C

Block Diagram of Test Setup:

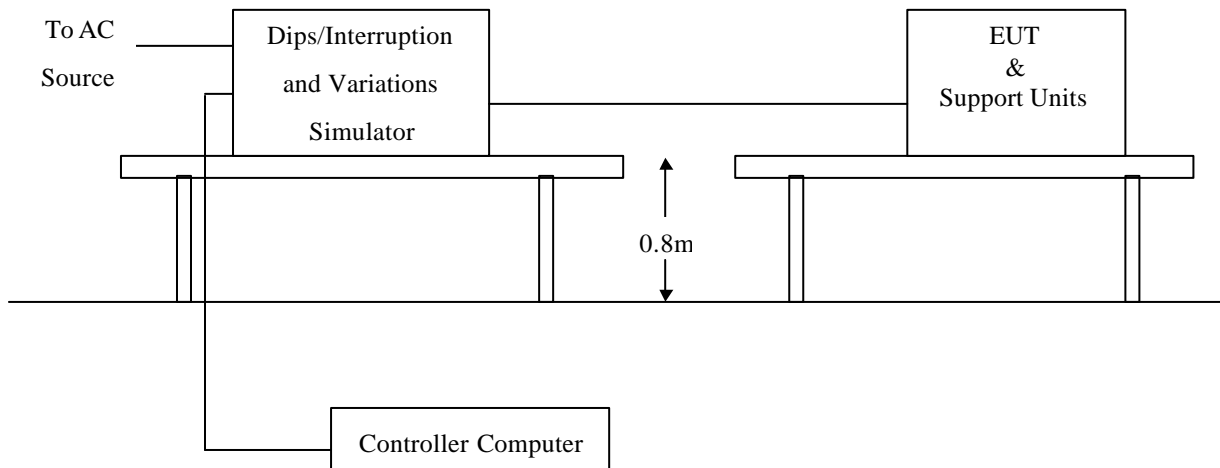

Test Procedure:

1. The EUT and support units were located on a wooden table, 0.8 m away from ground floor.
2. Set the parameter of tests and then Performed the test software of test simulator.
3. Changed Condition to occur at 0 degree crossover point of the voltage waveform.
4. Recorded the test result in test record form.

**Test conditions:**

The duration with a sequence of three dips/interruptions with interval of 10 s minimum
(Between each test event)

Test Level % U _T	Reduction (%)	Duration (periods)	Observation	Meet Performance Criteria
70	30	0.5	N/A	N/A
40	60	5	N/A	N/A
40	60	50	N/A	N/A
< 5	> 95	250	N/A	N/A

Normal: No any functions degrade during and after the test.

Performance & Result:

Criterion A: The apparatus continues to operate as intended. No degradation of performance or loss of function is allowed below a performance level specified by the manufacturer, when the apparatus is used as intended. In some cases the performance level may be replaced by a permissible loss of performance.

Criterion B: The apparatus continues to operate as intended after the test. No degradation of performance or loss of function is allowed below a performance level specified by the manufacturer, when the apparatus is used as intended. In some cases the performance level may be replaced by a permissible loss of performance. During the test, degradation of performance is however allowed.

Criterion C: Temporary loss of function is allowed, provided the functions self recoverable or can be restored by the operation of controls.

PASS **FAIL**

Observation: The subject equipment is not intended to be connected to AC mains supply. Therefore, this test is not applicable.

APPENDIX I - PHOTOGRAPHS OF TEST SETUP

RADIATED EMISSION TEST EN 55022



EN 55011



ELECTROSTATIC DISCHARGE TEST

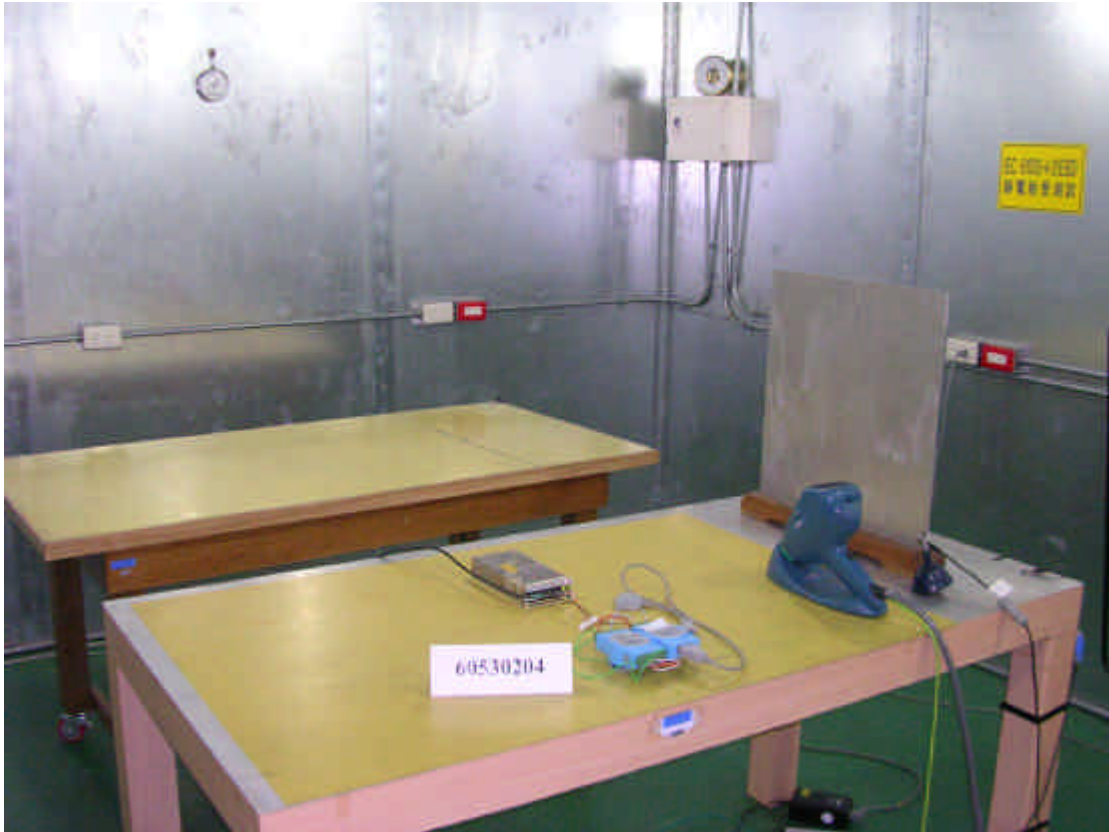

RADIATED ELECTROMAGNETIC FIELD TEST

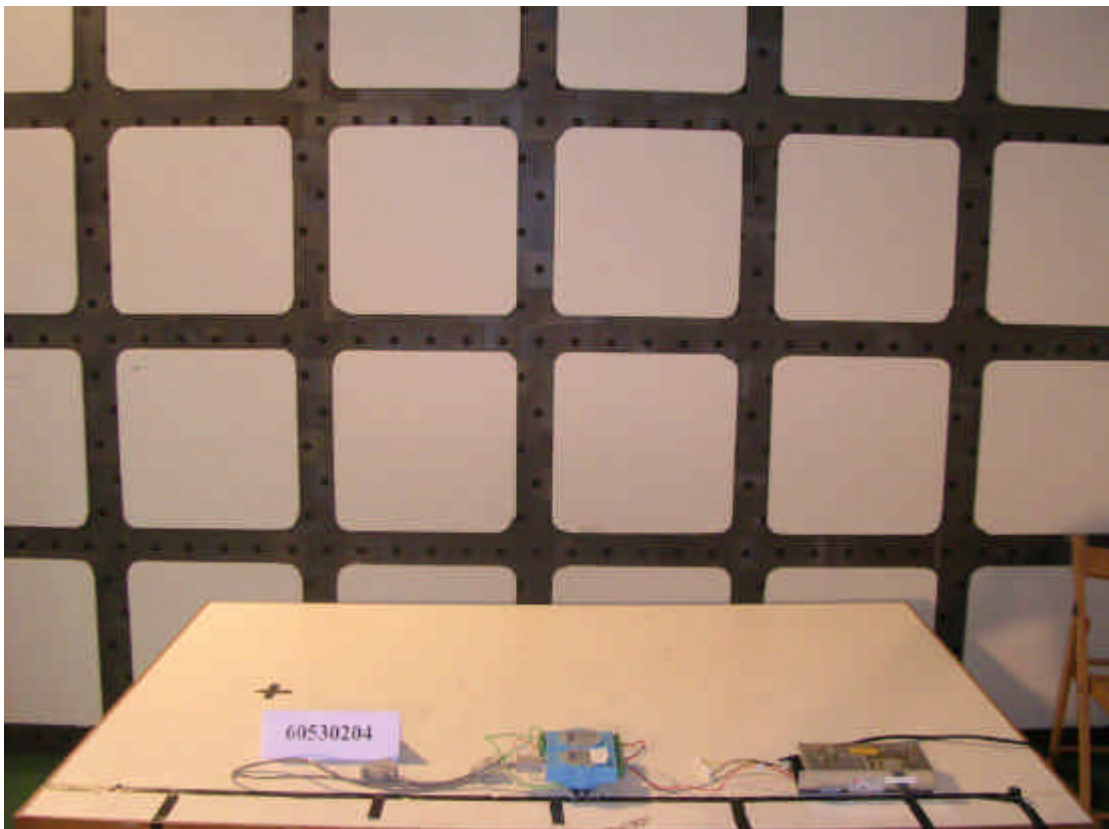

FAST TRANSIENTS/BURST TEST



SURGE IMMUNITY TEST



CONDUCTED DISTURBANCE, INDUCED BY RADIO-FREQUENCY FIELDS TEST

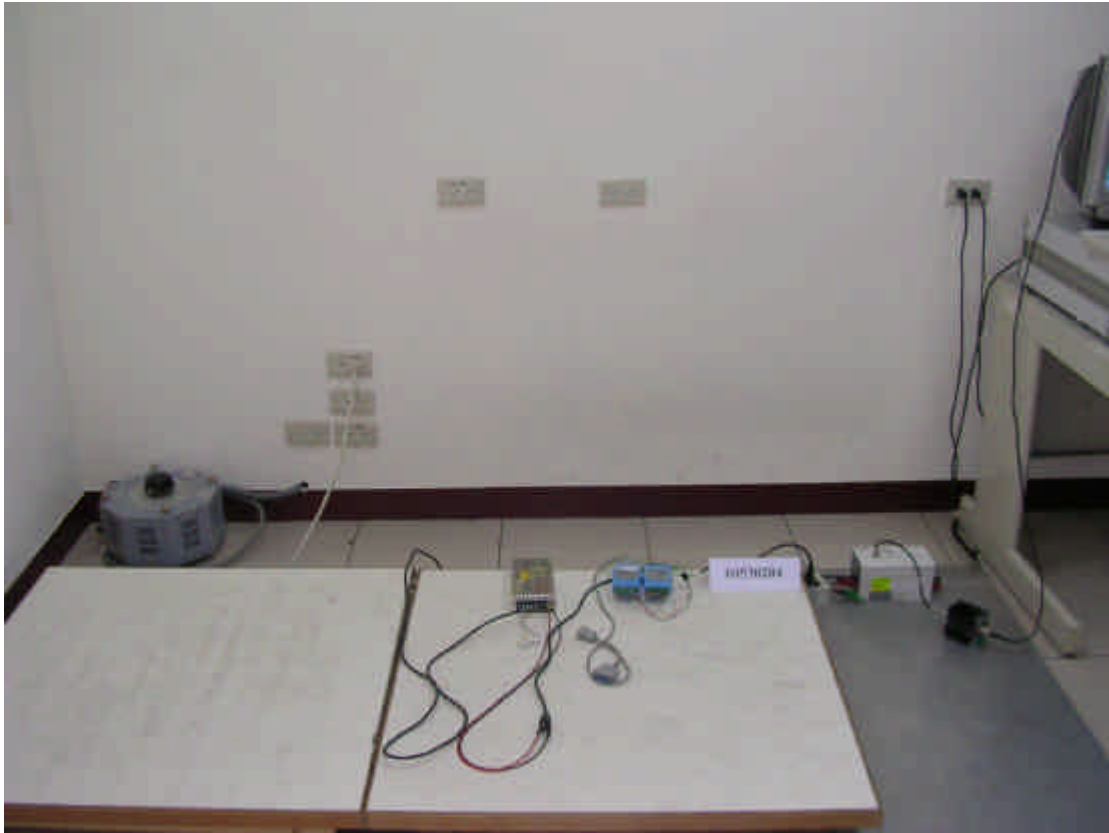

POWER FREQUENCY MAGNETIC FIELD IMMUNITY TEST

