

50 mm INFRA-RED OPTICAL TRACKBALL

L50

Utilizing the latest and most advanced infra-red optical tracking technology, the L50 Series Trackerball™ is an extremely high specification, contact-less device, ideal for the most demanding of cursor control applications.

The infra-red optical tracking engine provides accurate cursor motion at all speeds and on virtually any ball, combining the benefits of solid state sensing (no moving parts except the ball).

The L50 trackballs are available with a variety of electrical outputs, tracking force options, and sealing capabilities up to IP68.

The solid state design allows the device to be subjected to extreme conditions and provides the user with the ability to wash down, decontaminate, and sterilise, making it the ideal trackball for a wide range of demanding applications and environments.

The unit has been designed to be back of panel mounted as part of OEM keyboards and consoles.



SPECIFICATIONS

Mechanical

Weight	150 grams / 210 grams (removable ball)
Ball	Epoxy Resin, 50,8 mm
Tracking Force	10 grams Nominal Free Running 80 grams Nominal Friction / Scraper Ring 10 - 160 grams Nominal / Removable Ball
Ball Load	200N Maximum downward pressure (20 Kg) for 2 mins.
Ball Rotation	Continuous and reversible any direction
Resolvable Ball Speed	40 Inches/sec.
Housing Material	Polycarbonate / ABS
Tracking engine	Infra-red Optical Navigation Technology (solid state sensing)
Mounting Position	All angles
Sealing gasket	Cellular silicone

Electrical

Supply voltage	4.4V to 5.25V D.C.
Supply current	80mA typical, 85mA maximum
Resolution	800 counts per ball revolution +/- 10% (Quadrature protocol) 1200 counts per ball revolution @ 5 IPS (inches per second) +/- 10% (USB, PS/2 protocol)
Output connector	10 Way, right-angled JST header, part no: S10B-PH-SM3-TB
Switch Inputs (USB, PS/2)	3 switches: left, middle, and right. Connection through 4-way JST, right-angled header, part no: S4B-PH-SM3-TB

Environmental

Operating temperature	0°C to +55°C (IEC 60068-2-1, IEC60068-2-2)
Storage temperature	-40°C to +85°C (IEC 60068-2-1, IEC60068-2-2)
Operating humidity	93% RH @ 40°C, non-condensing (IEC 60068-2-78)
Storage humidity	10%-95% non-condensing (IEC 60068-2-78)
Vibration	2g, 10-500Hz, 1 octave/min, 10 sweep cycles (IEC 60068-2-6)
Operating Shock	15g/11ms, ½ sine, 3 shocks in +ve and -ve direction, all 3 axes (IEC 60068-2-27)
Non-operating shock	50g/11ms, ½ sine, 3 shocks in +ve and -ve direction, all 3 axes (IEC 60068-2-27)
Impact	20Joules
Mechanical lifetime	1 million ball revolutions
MTBF	in excess of 80,000 hours (MIL-STD-217F)
ESD	15kV air-discharge and 8kV contact discharge (IEC 61000-4-2)
EMC	Radiated immunity - limits according to level 3 of IEC 61000-4-3 Radiated emissions to EN55022 class A
Sealing capability	IP68 (BS EN 60529)

- Sealing to IP68
- Solid state sensing technology - Infra-red optical tracking engine
- Smooth operation in rugged environments
- 3 versions
 - Free running ball : minimal ball tracking force
 - Fixed friction/scraper ring : slightly increased ball tracking force
 - Removable ball
- Custom connector options possible
- Self draining and back flushing features
- Vx3™ integrated zoom feature for scroll wheel functionality
- Self draining and back flushing features
- Outputs : Quadrature, USB & PS/2

50 mm INFRA-RED OPTICAL TRACKBALL

DIMENSIONAL DRAWING

Dimensions for free running and fixed friction/scrapper devices

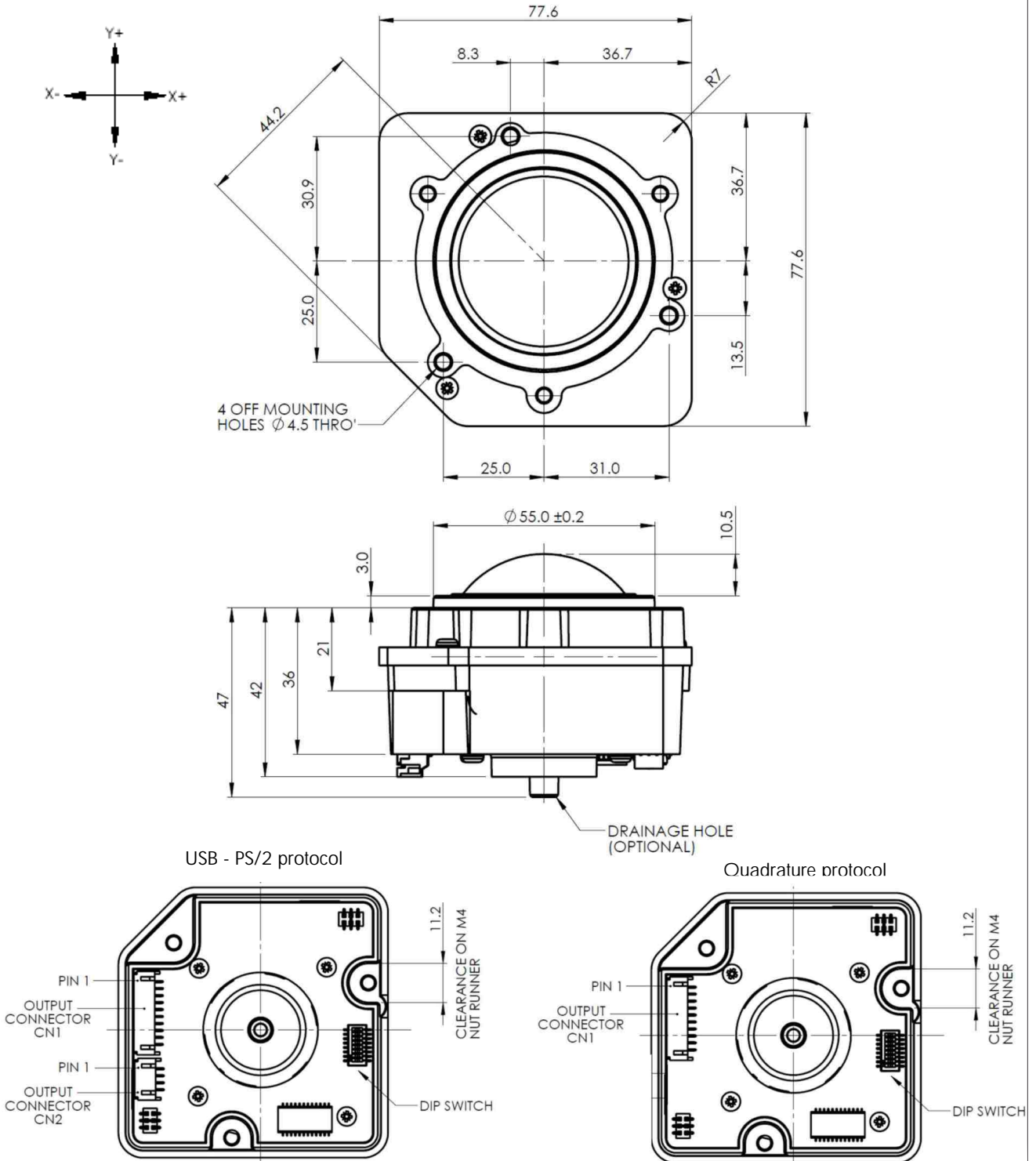

The company reserves the right to alter without prior knowledge the specification or design of any standard product or service.

50 mm INFRA-RED OPTICAL TRACKBALL

DIMENSIONAL DRAWING

Dimensions for Variable Friction / Removable Ball device

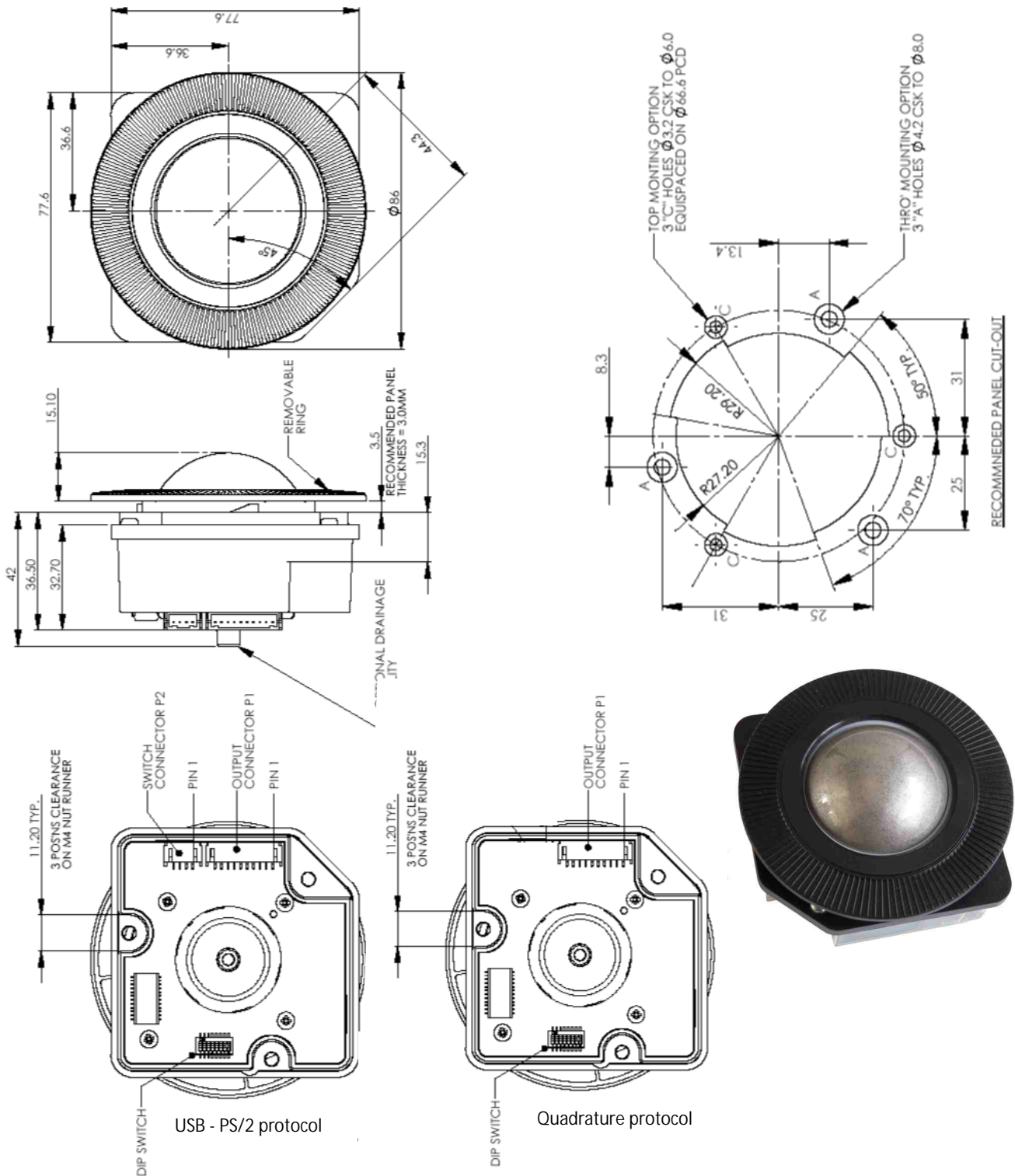

The company reserves the right to alter without prior knowledge the specification or design of any standard product or service.

50 mm INFRA-RED OPTICAL TRACKBALL

CONNECTION DETAILS QUADRATURE OUTPUT

Output Connector : P1

Description: 10 Way JST, right-angled header.
 Manufacturer: JST (or equivalent)
 Part No: S10B-PH-SM4-TB
 Mating connector: PH, CR or KR types (e.g. PHR-6)

Pin Number	Quadrature
1	X1
2	X2
3	Y1
4	Y2
5	EARTH
6	EARTH
7	5V D.C
8, 9	See note 1
10	0V

Note 1 : Pin to be left floating (unconnected)

CONNECTION DETAILS PS/2 - USB OUTPUT

Output Connector : P1

Description: 10 Way JST, 2 mm pitch, right-angled header.
 Manufacturer: JST (or equivalent)
 Part No: S10B-PH-SM4-TB
 Mating connector: PH, CR or KR types

Switch Input Connector : P2

Description: 4-way JST, right-angled header.
 Manufacturer: JST (or equivalent)
 Part No: S4B-PH-SM4-TB
 Mating connector: PH, CR or KR types

Pin Number	USB/PS/2
1, 2, 3 or 4	See note 1
5	EARTH
6	EARTH
7	5V D.C
8	PS/2 Data, D-
9	PS/2 Clock, D+
10	0V

Pin Number	Function
1	Left switch
2	Middle switch
3	Right switch
4	0V

Note 1 : Pin to be left floating (unconnected)

Switch Schematic

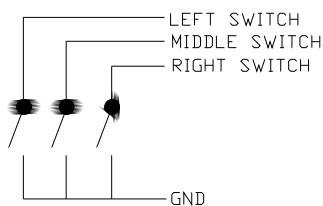

OPTIONAL LEAD ASSEMBLIES

Standard Lead assemblies for connection to the L50 unit are available. Other lead assemblies can also be supplied to customer specifications.

Part Number	Leads / Adapters	Description
OC5010160	Output cable USB	1,6 m shielded cable with USB type A plug
OC6010160	Output cable PS/2	1,6 m shielded cable with 6 pin mini DIN plug
IC040035	Switch Input	4 way JST style - bare wires, 35 cm long
IC101035	Interconnection	Interconnection cable, 35 cm long for quadrature output

50 mm INFRA-RED OPTICAL TRACKBALL

CONFIGURATION

The L50 trackball provides features that may be selected using the DIP switch located on the printed circuit board. This table details the assigned function of each switch.

DIP Switch Functions quadrature Trackballs

DIP Switch	Function	OFF	ON
1	Orientation 1 Setting	See Figure.1	See Figure.1
2	Orientation 2 Setting	See Figure.1	See Figure.1
3	Factory setting	Switch must be set in the OFF position	
4	Resolution	1200CPR*	600 CPR*
5	Inverted Y-axis	Feature disabled	Feature enabled
6	Factory setting	Switch must be set in the OFF position	
7	Factory setting	Switch must be set in the OFF position	
8	Factory setting	Switch must be set in the OFF position	

Factory default setting: All DIP switches OFF

*Counts per revolution

DIP Switch Functions PS/2 - USB Trackballs

DIP Switch	Function	OFF	ON
1	Orientation 1 Setting	See Figure.1	See Figure.1
2	Orientation 2 Setting	See Figure.1	See Figure.1
3	VX3 - Virtual 3 Axis Function	Feature disabled	Feature enabled
4	Smart Feature	Feature disabled	Feature enabled
5	Tracking mode	Ballistic tracking	Linear tracking
6	Factory setting	Must be OFF	Must be OFF
7	Resolution	1200CPR*	600CPR*
8	Factory setting	Switch must be set in the OFF position	

Factory default setting: All DIP switches OFF

*Counts per revolution

Orientation

The orientation function allows the user to mount the L50 Series trackball device in one of four positions (see figure. 1 below). The orientation of the device is determined by the direction in which the output connector is facing (when viewed from the top of Trackerball device). The direction of the connector is indicated by the arrow.

The Trackerball orientation can be selected to accommodate customer requirements for connector location and wiring.

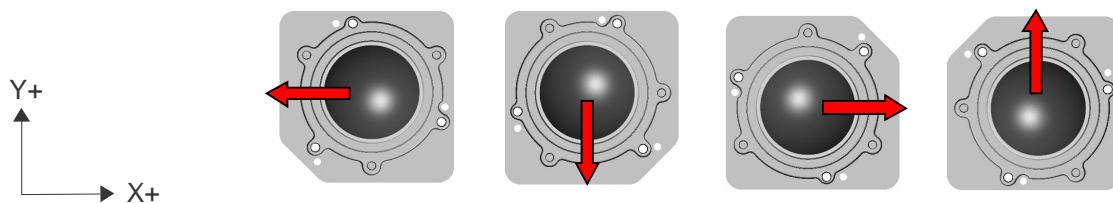

Switch 1	Orientation 1	Off	On	Off	On
Switch 2	Orientation 2	Off	Off	On	On

Figure.1 Mounting Orientations

50 mm INFRA-RED OPTICAL TRACKBALL

CONFIGURATION

VX3™

VX3 is patent protected facility that provides the same 2 modes of functionality as a scroll wheel on a 3-axis mouse.

Operation:

Press middle button once to latch scroll mode one (e.g. dynamic pan feature);

Press middle button again to latch scroll mode two (e.g. 3rd axis zoom feature);

Further middle button presses toggles between scroll mode one and scroll mode two;

Press either left or right buttons to cancel feature and resume normal X-Y cursor operation

Smart Switch

A patent protected button latch facility.

Operation:

Press right button for 3 seconds or more to enable;

Once enabled, pressing any button for approximately 1 second latches that button on;

Press any button momentarily to de-latch;

Disabled with a further press of the right button for 3 seconds or more;

Tracking Mode

Ballistic Tracking: Intuitive tracking algorithm to provide increased cursor resolution when tracking fast whilst retaining the original resolution for tracking accurately at slow speeds.

Linear Tracking: No tracking algorithm. 1200/600 counts per ball revolution maintained at all tracking speeds.

ORDER INFO

OUTPUT	DRAINING	FREE RUNNING	FIXED FRICTION RING	REMOVABLE BALL
Quadrature	No draining	L50-70020D	L50-70021D	L50-70024D
	Self draining	L50-70025D	L50-70026D	L50-70027D
PS/2 & USB	No draining	L50-76020D	L50-76021D	L50-76024D
	Self draining	L50-76025D	L50-76026D	L50-76027D

NSI stock types : L50-70021D / L50-76020D / L50-76021D / L50-76024D / L50-76027D

OPTIONAL EXTRAS

- Optional Ball Colours (MOQ applies)
- Customer Specific Colour Matching (MOQ applies)
- Custom lead Assemblies

Contact your local distributor for further details on product variants and custom specifications.

MANUFACTURER

Cursor Controls Ltd, Brunel Drive,
Newark, U.K
Tel: ++44 (0) 1636 615600
Fax: ++44 (0) 1636 615601
Website : www.cursorcontrols.com
E-mail: sales@cursorcontrols.com



EUROPEAN SALES & SERVICE CENTER

NSI bvba, Haakstraat 1A,
B-3740 Bilzen, Belgium
Tel. : +32 89 51 90 00
Fax : +32 89 91 90 09
Website : www.nsi-be.com
E-mail : info@nsi-be.com

